



*Setting the Standard with the
World's Most Valued Grinders.*

MODEL 673 AUTOMATIC BEDKNIFE GRINDER

This book consists of two manuals:

The OPERATOR'S MANUAL contains all the information on operating and routine daily maintenance on this equipment.

The SERVICE MANUAL is to be used by the maintenance department to do all maintenance except routine daily maintenance.



*Setting the Standard with the
World's Most Valued Grinders.*

We are committed to:

Providing superior customer support, training, and service.

Manufacturing the highest quality products at an unequaled value.

Setting the industry standard by investing in technological product innovation.

Manufacturing products specifically designed to maintain original equipment manufacturers' specifications.

Interacting with and supporting all original equipment manufacturers.

MODEL 673 AUTOMATIC BEDKNIFE GRINDER

OPERATOR'S MANUAL

 **WARNING**

You must thoroughly read and understand all manuals before operating the equipment, paying particular attention to the Warning & Safety Instructions.

IMPORTANT SAFETY MESSAGE

This manual will cover the installation and operation of this Bedknife Grinder. There is an additional manual that addresses the service of this equipment. As manufacturers of bedknife grinders, we want to emphasize our concern for safety. We also want to remind you about the simple, basic, and common sense rules of safety when using a bedknife grinder. Failure to follow these rules can result in severe injury or death to operators or bystanders.

It is essential that everyone involved in the assembly, operation, transport, maintenance, and storage of this equipment be aware, concerned, prudent, and properly trained in safety. Always use proper shielding and personal protective equipment as specified by the manufacturer.

Our current production machines include, as standard equipment, guards or shields for the grinding wheel, safety signs, and operator's and service manuals. Never bypass or operate the machine with any of the guards or safety devices removed, or without the proper personal safety equipment.

Read and fully understand all the safety practices discussed in this manual. All safety rules must be understood and followed by anyone who works with bedknife grinders.

Before operating a bedknife grinder, an operator must read and understand all of the information in the Operator's Manual and understand all the safety signs attached to the product. A person who has not read or understood the Operator's Manual and safety signs is not qualified to operate the unit. Accidents occur often on machines that are used by someone who has not read the Operator's Manual and is not familiar with the equipment. If you do not have an Operator's Manual or current production safety signs, contact the manufacturer or your dealer immediately.

Bedknife grinders are designed for one-person operation. Never operate the grinder with anyone near, or in contact with, any part of the grinder. Be sure no one else, including bystanders, are near you when you operate this product.

Following these simple, basic safety rules, as well as others:

- Find and understand all safety signs in the operators manual and on the equipment. This will help minimize the possibility of accidents and increase your productivity in using this product.
- Be careful and make sure that everyone who operates the grinder knows and understands that it is a very powerful piece of machinery, and if used improperly, serious injury or death may result.
- The final responsibility for safety rests with the operator of this machine.

Throughout this manual, the following safety symbols will be used to indicate the degree of certain hazards.



This symbol is used to indicate important information.



This symbol is used throughout this manual to call attention to the safety procedures.

! DANGER

The word **DANGER** indicates an immediate hazardous situation, which if not avoided, will result in death or serious injury.

! WARNING

The word **WARNING** indicates a potential hazardous situation, which if not avoided, could result in death or serious injury.

! CAUTION

The word **CAUTION** preceded with a safety alert symbol indicates a potential hazardous situation which, if not avoided, may result in minor or moderate injury.

TABLE OF CONTENTS

Specifications..... Page 6
 Maintenance Page 7
 Safety Instructions..... Pages 8 - 11
 Installation Instructions..... Pages 12 - 16
 Getting to Know your Grinder Pages 17 - 24
 General Operating Instructions Pages 25 - 32

READ OPERATOR'S MANUAL

Read the Operator's Manual before operating this equipment. Keep this manual handy for ready reference. Require all operators to read this manual carefully and become acquainted with all adjustments and operating procedures before attempting to operate the equipment. Replacement manuals can be obtained from your selling dealer or the manufacturer.

The equipment you have purchased has been carefully engineered and manufactured to provide dependable and satisfactory use. Like all mechanical products, it will require cleaning and upkeep. Lubricate and clean the unit as specified in the Operator's Manual. Please observe all safety information in this manual, the Operators Manual, and the safety decals on the equipment.

PREPARATION/INSTALLATION CHECK LIST

Before using this equipment refer to the list below. Verify that all of the listed items are completed before powering up the equipment:

1. Equipment is completely assembled
2. All shields are in place and in good condition.
3. All decals are in place and readable.
4. Overall condition of machine is good (i.e. paint, welds, electrical).
5. Verify there is sufficient electrical power to operate the machine.
6. Read and understand all areas of the Operator's Manual, and review the Service Manual, and any additional training material if available.
7. Understand general maintenance.

Keep this manual handy for ready reference. Require all operators to read this manual carefully and become acquainted with all adjustments and operating procedures before attempting to operate the equipment. Replacement manuals can be obtained from your selling dealer or the manufacturer.

The equipment you have purchased has been carefully engineered and manufactured to provide dependable and satisfactory use. Like all mechanical products, it will require periodic cleaning and upkeep. Lubricate and clean the unit as specified. Please observe all safety information in this manual and safety decals on the equipment.

This machine is intended for grinding the bedknife from a reel type mowing unit ONLY. Any other use may cause personal injury and void the warranty.

To assure the quality and safety of your machine and to maintain the warranty, you MUST use original equipment manufactures replacement parts and have any repair work done by a qualified professional.

ALL operators of this equipment must be thoroughly trained BEFORE operating the equipment.



Do not use compressed air to clean grinding dust from the machine. This dust can cause personal injury as well as damage to the grinder. This machine is designed for indoor use only. DO NOT powerwash this machine.



SPECIFICATIONS

Electrical Requirements.....	115VAC 50/60 Hz, 15-amp circuit
Electrical Requirements with transformer	230VAC 50/60 Hz, 8-amp circuit
Net Weight	820 lbs [372 kg]
Shipping Weight	920 lbs [417 kg]
Maximum Grinding Length.....	34 in. [863 mm]
Sound Level	Less than 75 Db

OPERATING CONDITIONS:

THIS MACHINE IS INTENDED FOR INDOOR USE ONLY.

AMBIENT TEMPERATURE:.....	+5°C/ 40°F to +40°C/ 100°F
RELATIVE HUMIDITY:.....	50% RH, +40°C / 100°F. Higher humidity may be allowed at lower temperatures.No condensation must be present.
ALTITUDE:	up to 1000m/ 3280 ft. above mean sea level.
TRANSPORTATION AND STORAGE:.....	-25°C/-15°F to +55°C / 130°FMeans must be provided to prevent damage from humidity, vibration and shock.

LOW VOLTAGE RELAY (LVR)



The grinder is equipped with a high-low voltage relay which is factory preset at 100-140 VAC. If the power supply line does not deliver 100-140 VAC power under load, the relay will open and trip out the starter. If this occurs, your power supply line is incorrect and must be corrected before proceeding further with the grinder.

WARNING

FACTORY
 PRESET.
 FLASHING
 GREEN LIGHT
 INDICATES
 LOW VOLTAGE.
 FLASHING
 RED LIGHT
 INDICATES
 HIGH VOLTAGE
 DELIVERED
 TO GRINDER

OPERATOR MAINTENANCE

On a daily basis:

1. Clean the grinder by wiping all areas down.



DO NOT USE COMPRESSED AIR TO CLEAN GRINDING DUST FROM THE GRINDER.

2. Check coolant tray fluid level.
3. Inspect the grinder for loose fasteners or components and tighten. Contact your company's Maintenance Department if damaged or defective parts are found.

Periodically (to be performed by your company's maintenance department):

1. Clean the right side adjustable electromagnet bearing rail weekly. Lift the bellows located on the adjustable electromagnet (see FIG. 1) and wipe off the bearing rail. Every month thoroughly clean the rail and flood spray with CRC 3-36 or an equivalent lubricant. Move the adjustable electromagnet back and forth through its full range of travel. With a clean rag, wipe off the excess lubricant. Move the carriage back and forth and wipe the rail after each pass. Repeat until the rail feels dry.
2. Thoroughly clean the traverse rails weekly. Flood spray with CRC 3-36 or an equivalent lubricant, if the optional traverse carriage bellows are installed lift to access the traverse rails (See FIG. 2). Move the carriage back and forth through its full range of travel. With a clean rag, wipe off the excess lubricant. Move the carriage back and forth and wipe the rail after each pass. Repeat until the rail feels dry.
3. Clean the interior and the top cover of the Coolant Tank as necessary and at least once every 12 months.
4. Replace the four foam rail wipers (FIG. 3) every 6 months of operation. Note: If optional bellows are installed the foam wipers are removed.
5. Clean the exterior of the diamond dresser arm and spray with CRC 3-36 or equivalent at least every 6 months.
6. Clean the exterior of the grinding head height adjuster and spray with CRC 3-36 or equivalent at least every 6 months. Move head through full range of motion to maintain function.
7. Clean the exterior of the right side tooling alignment adjuster and spray with CRC 3-36 or equivalent at least every 6 months.
8. Check the brushes on the auto traverse drive motor once every 36 months. Replace as necessary.

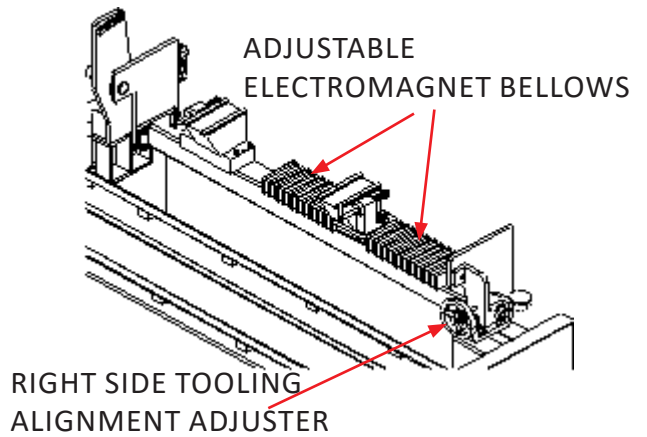

FIG. 1

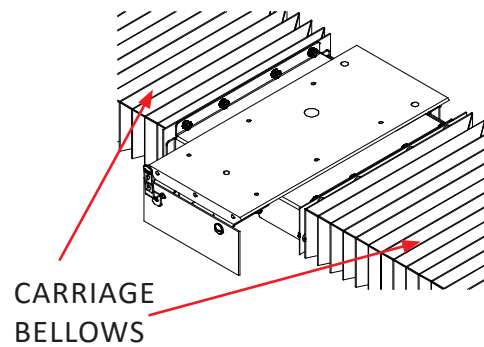

FIG. 2

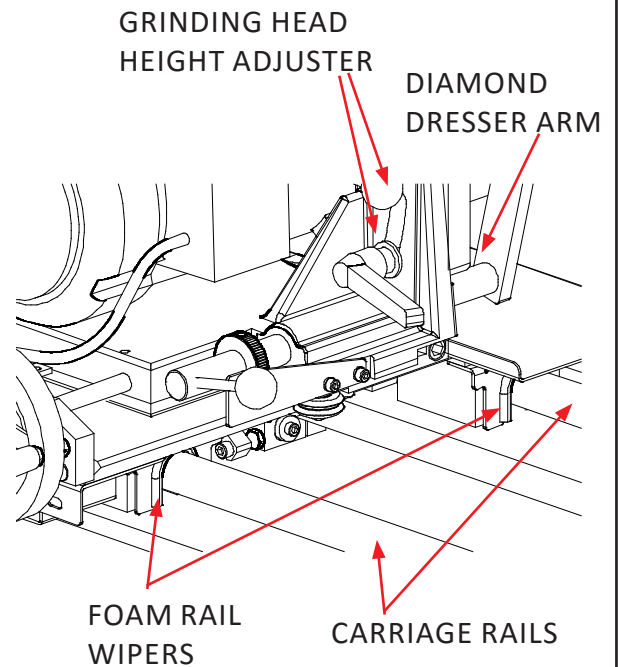

FIG. 3

 **WARNING**

TO AVOID INJURY, READ AND UNDERSTAND THE SAFETY ITEMS LISTED BELOW. IF YOU DO NOT UNDERSTAND ANY PART OF THIS MANUAL AND NEED ASSISTANCE, CONTACT YOUR LOCAL DEALER OR THE MANUFACTURER.

- 1. KEEP GUARDS IN PLACE** and in working order.
- 2. REMOVE WRENCHES AND OTHER TOOLS.**
- 3. KEEP WORK AREA CLEAN.**
- 4. DON'T USE IN DANGEROUS ENVIRONMENT.**
Don't use the grinder in damp or wet locations. This machine is for indoor use only. Keep the work area well lit.
- 5. KEEP ALL VISITORS AWAY.** All visitors should be kept a safe distance from the work area.
- 6. MAKE THE WORK AREA CHILD-PROOF** with padlocks or master switches.
- 7. DON'T FORCE THE GRINDER.** It will do the job better and safer if used as specified in this manual.
- 8. USE THE RIGHT TOOL.** Don't force the grinder or an attachment to do a job for which it was not designed.
- 9. WEAR PROPER APPAREL.** Wear no loose clothing, gloves, neckties, or jewelry which may get caught in moving parts. Nonslip footwear is recommended. Wear protective hair covering to contain long hair. Wear a respirator or filter mask where appropriate. Wear protective gloves.
- 10. ALWAYS USE SAFETY GLASSES.**
- 11. SECURE YOUR WORK.** Make certain that the cutting unit is secured with the electromagnets before operating.
- 12. DON'T OVERREACH.** Keep proper footing and balance at all times.
- 13. MAINTAIN GRINDER WITH CARE.** Follow instructions in the Operator's and Service Manuals for lubrication and preventive maintenance.
- 14. DISCONNECT POWER BEFORE SERVICING,** or when changing the grinding wheel.
- 15. REDUCE THE RISK OF UNINTENTIONAL STARTING.** Make sure that all switches are OFF and the emergency-stop is pressed in before plugging in the machine.
- 16. USE ONLY RECOMMENDED ACCESSORIES.** Consult the manual for recommended accessories. Using improper accessories may cause risk of personal injury or damage to the equipment.
- 17. CHECK FOR DAMAGED PARTS.** A guard or other part that is damaged or will not perform its intended function should be properly repaired or replaced.
- 18. NEVER LEAVE THE GRINDER RUNNING UNATTENDED. TURN THE POWER OFF.** Do not leave grinder until it comes to a complete stop.
- 19. KNOW YOUR EQUIPMENT.** Read this manual carefully. Learn its application and limitations as well as the specific potential hazards.
- 20. KEEP ALL SAFETY DECALS CLEAN AND LEGIBLE.** If safety decals become damaged or illegible for any reason, replace immediately. Refer to replacement parts illustrations in the Service Manual for the proper location and part numbers of safety decals.
- 21. DO NOT OPERATE GRINDER WHEN UNDER THE INFLUENCE OF DRUGS, ALCOHOL, OR MEDICATION.**

 **WARNING**
IMPROPER USE OF GRINDING WHEEL MAY CAUSE BREAKAGE AND SERIOUS INJURY.

Grinding is a safe operation if the few basic rules listed below are followed. These rules are based on material contained in the ANSI B7.1 Safety Code for "Use, Care and Protection of Abrasive Wheels". For your safety, we suggest you benefit from the experience of others and carefully follow these rules.

- | DO | DON'T |
|---|--|
| 1. DO always HANDLE AND STORE wheels in a CAREFUL manner. | 1. DON'T use a cracked wheel or one that HAS BEEN DROPPED or has become damaged. |
| 2. DO VISUALLY INSPECT all wheels before mounting for possible damage. | 2. DON'T FORCE a wheel onto the machine OR ALTER the size of the mounting hole. If the wheel won't fit the machine, get one that will. |
| 3. DO CHECK MACHINE SPEED against the established maximum safe operating speed marked on the wheel. | 3. DON'T EXCEED THE MAXIMUM OPERATING SPEED established for the wheel. |
| 4. DO CHECK MOUNTING FLANGES for equal and correct diameter. | 4. DON'T use mounting flanges on which the bearing surfaces ARE NOT CLEAN, FLAT AND FREE OF BURRS . |
| 5. DO USE MOUNTING BLOTTERS that are supplied with the wheels. | 5. DON'T TIGHTEN the mounting nut excessively. |
| 6. DO be sure WORK REST is properly adjusted. | 6. DON'T grind on the SIDE OF THE WHEEL (see Safety Code B7.2 for exception). |
| 7. DO always USE A SAFETY GUARD COVERING at least one-half of the grinding wheel. | 7. DON'T start the machine until the WHEEL GUARD IS IN PLACE . |
| 8. DO allow NEWLY MOUNTED WHEELS to run at operating speed, with guard in place, for at least one minute before grinding. | 8. DON'T JAM the work into the wheel. |
| 9. DO always WEAR SAFETY GLASSES or some type of approved eye protection when grinding. | 9. DON'T STAND DIRECTLY IN FRONT of a grinding wheel whenever a grinder is started. |
| 10. DO TURN OFF COOLANT before stopping to avoid creating an out-of-balance condition. | 10. DON'T FORCE THE GRINDING so that motor slows noticeably or that the work piece gets hot. |

 **WARNING**

AVOID INHALATION OF DUST generated by grinding and cutting operations. Exposure to dust may cause respiratory ailments. Use approved NIOSH or MSHA respirators, safety glasses or face shields, and protective clothing. Provide adequate ventilation to eliminate dust, or to maintain dust level below the Threshold Limit Value for nuisance dust as classified by OSHA.



SAFETY DECALS - LOCATION.

If any decals are damaged, replace them immediately!

See next page for explanation of symbols and decals.

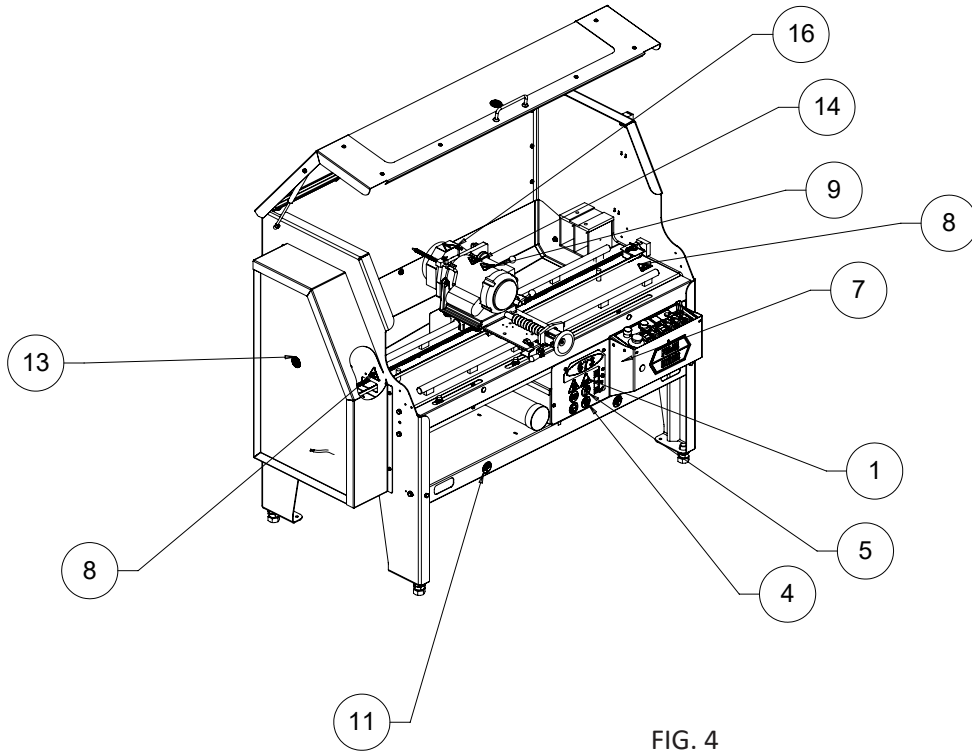

FIG. 4

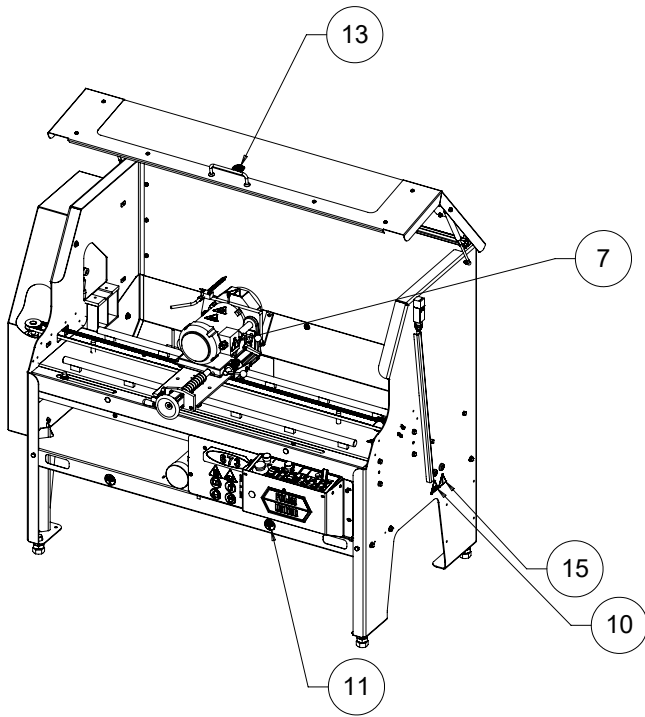

FIG. 5

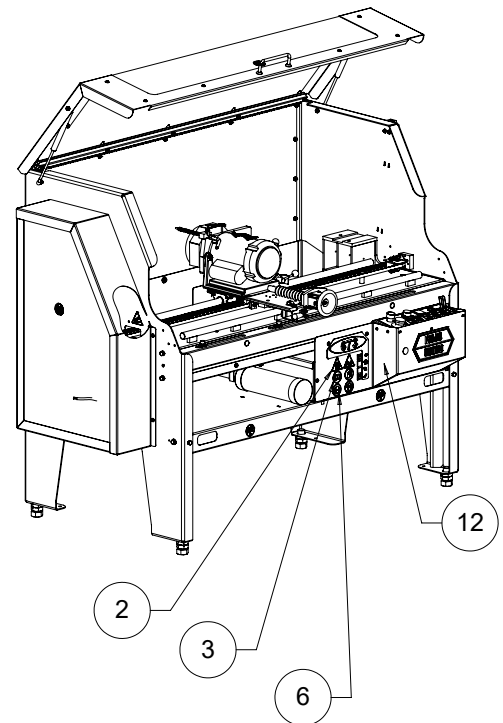

FIG. 6



READ AND UNDERSTAND AND LOCATE ALL DECALS ON THIS MACHINE BEFORE OPERATING THIS EQUIPMENT.

1



Keep visitors at a safe distance away from the equipment.

2



Read Service manual and disconnect power before servicing.

3



Refer to manual— after installation, read the user's guide carefully before operating. Follow all operating and other instructions carefully.

4



WARNING! Use of proper eyewear is mandatory when operating this equipment.

5



WARNING! Gloves or other **hand protection is required** when operating this equipment.

6



WARNING! Operators and people in close proximity **must wear respirators or have adequate ventilation systems.**

7



This is the electrical hazard symbol. It indicates that there are **DANGEROUS HIGH VOLTAGES PRESENT** inside the enclosure of this product. **TO REDUCE THE RISK OF FIRE OR ELECTRIC SHOCK, do not attempt to open the enclosure or gain access to areas where you are not instructed to do so. REFER SERVICING TO QUALIFIED SERVICE PERSONNEL ONLY.**

8



Entanglement Hazard. Keep clear of belt.

9



Sharp object in the vicinity which may cause injury. **Keep hands clear of sharp edges!**

10



Power cord may be a trip hazard. Secure the power cord in a manner that removes it as a trip hazard.

11



Use a Fork Lift with a minimum of 48" [122cm] long forks to move this Equipment. Lift only where indicated on the machine. Failure to use proper lifting equipment may result in personal injury or damage to the equipment.

12

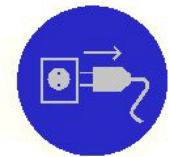

Unplug the machine when servicing or storing for an extended period of time.

13



WARNING! Do Not Operate Without Guards and Covers in Place. There are moving parts located behind guard.

14

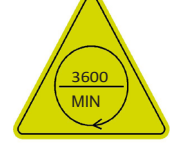

Shows the minimum speed [3600 RPM] that the grinding wheel must be rated for to use on this equipment.

15



POWER CORD PROTECTION – The power supply cord for this product acts as the main-disconnect. It should be routed or installed in such a manner to protect it from being walked on or pinched. The unit should be powered down completely before connecting or disconnecting the power cable. The power cord should be removed before moving the unit. **The power cord must be placed near an easily accessible unobstructed socket outlet.**

16



GRINDING WHEEL GUARD – Wheel guard should be positioned to cover the top of the wheel. If the wheel guard is rotated to provide clearance, always rotate back immediately afterwards.

NOTE: For clarity, the grinder is shown on the following pages without the **optional** carriage bellows installed.

UNPACK THE CARTONS

NOTE: Before you install the machine, read the following assembly procedure completely. Then study "Getting to Know Your Bedknife Grinder" in the Operator's Manual.

Use care when unpacking. Double-check the packing cartons for any miscellaneous items before discarding.

Inspect all items for shipping damage as they are removed from the shipping containers. If you find any damage, notify the carrier's claims agent and do not proceed further until the damage has been inspected by the agent. Refer also to the "Shipping and Receiving Instructions" packed with the unit.

REMOVE THE GRINDER FROM THE PALLET

To remove the grinder from the wood pallet:

1. Unbolt the grinder legs from the bottom pallet. (There are 2 - Lag bolts on each leg. See Fig 7.)
2. The grinder's four leveling feet (FIG. 8) are seated in countersunk holes in the pallet. Use a fork lift or other power equipment to raise the grinder from the wood base and set it in its final position. Lift under the bottom tray. The forks must reach to the rear of the machine and extend past or the grinder may be damaged while lifting.

WARNING

The grinder weighs 780 lbs [354 kg]. Use power equipment to lift.

3. After the grinder is set in place, remove the shipping strap that secures the grinding head and carriage to the left end of the machine during shipment. Discard the lag screw and the shipping strap.

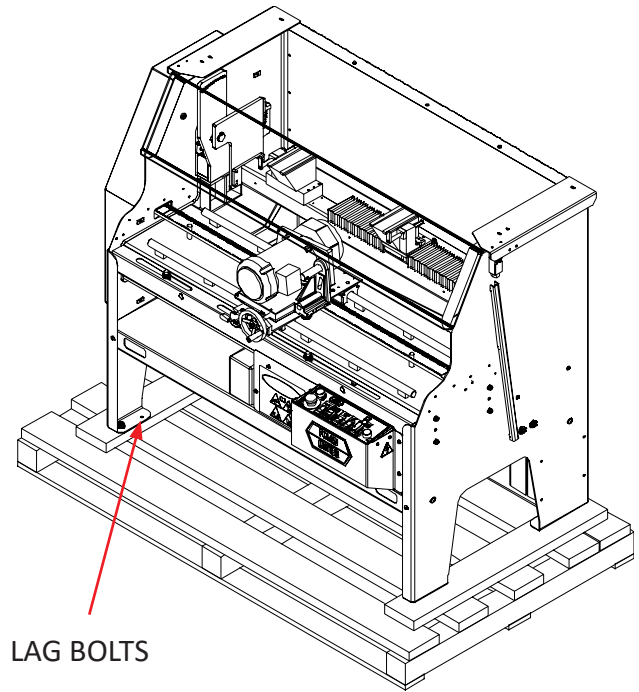

FIG. 7

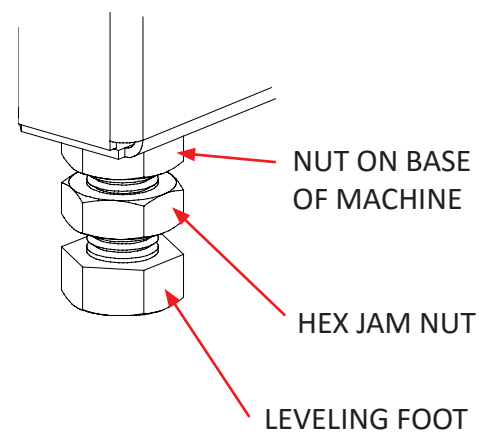

FIG. 8

LOCATE AND LEVEL THE GRINDER

Set the grinder on a level concrete floor, on a single uncracked slab of concrete.

If the unit must be located near a wall, allow adequate space for operating and servicing. Refer to FIG. 9 for recommended and alternate locations near a wall.

Place a level on the front carriage rail near the center of the machine and check the level from left to right. See FIG. 10. Adjust the leveling feet until the machine is level.

Place the level across the front and rear carriage rails near the left end of the machine. See FIG. 10. Adjust the two leveling feet on the left end until the rear rail (the one closest to the coolant tank) is slightly lower than the front rail--so any coolant on the carriage, main base, or optional bellows will drain back into the coolant tray.

Place the level across the front and rear carriage rails near the right end of the carriage bed. Level the right end in the same way as the left end. For grinding accuracy, the two ends must have the identical backward slant within $\pm .03$ " [$.75$ mm] so the frame is not twisted.

Recheck the level in both directions. When satisfactory, tighten the hex jam nuts on the leveling feet securely against the nuts welded to the bottom of the base. See FIG. 11.

! Make sure that the leveling feet don't turn when tightening the jam nuts.
● Recheck the level after the nuts are firmly tightened.

For grinding accuracy, the machine does not have to be perfectly level. However, it is important that front-to-back leveling be identical at both ends of the machine.

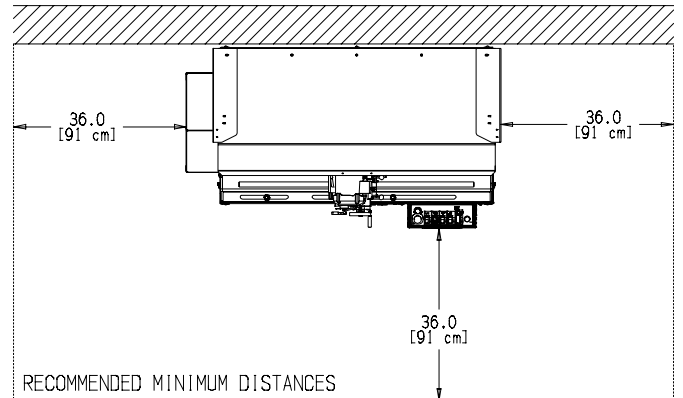

FIG. 9

LEVELING SIDE-TO-SIDE

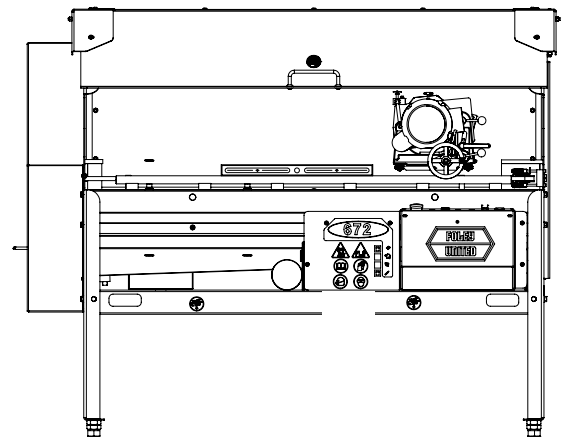

FIG. 10

LEVELING FRONT-TO-BACK

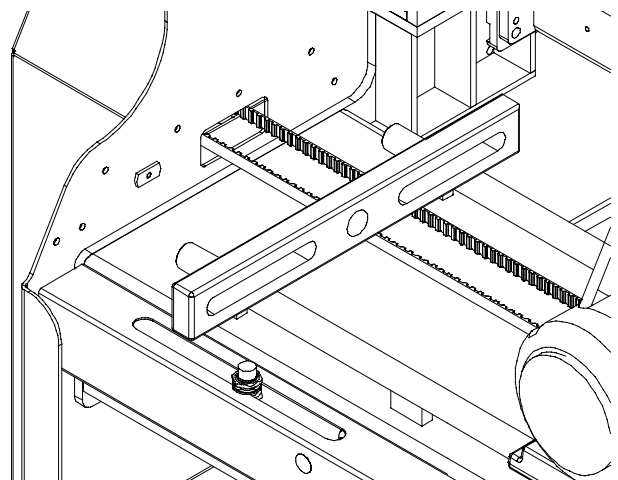

FIG. 11

APPLY POWER

WARNING

BEFORE YOU APPLY POWER TO THE GRINDER, REFER TO THE "IMPORTANT GROUNDING INSTRUCTIONS" ON PAGE 15.

115 VOLT MODEL ONLY. PLUG THE CONTROL BOX POWER CORD INTO A STANDARD 115V AC 15-AMP GROUNDED RECEPTACLE. SEE FIG. 12.

220 VOLT MODEL ONLY. FOR 220 VOLT APPLICATIONS ORDER PART NO. 6730951, WHICH INCLUDES A 220 TO 110 VOLT STEP DOWN TRANSFORMER. SEE DETAILS ON PAGE 15.



FIG. 12



It is recommended that this bedknife grinder has its own permanent power connection from the power distribution panel, with no other major power draw equipment on the same line.

It is required that the power delivered to this grinder is 115 VAC - 15 amps. The tolerance on this power requirement is +/- 5%. Therefore the minimum voltage REQUIREMENT is 109VAC with 15 amps. Voltage must be checked with all equipment under load (operating) on the circuit.



DO NOT operate this grinder with an extension cord.

DO NOT operate this grinder on a Ground Fault Circuit Interrupter (GFCI) circuit. The (GFCI) will trip constantly.

PROPER GROUNDING OF THE RECEPTACLE GROUND IN YOUR BUILDING MUST BE VERIFIED. IMPROPER GROUNDING IN YOUR BUILDING MAY CAUSE THE GRINDER TO MALFUNCTION.

When installing the grinder, the following guidelines should be used to establish the wire size between the power panel in your building and the grinder receptacle. Note that the wiring in your building must be per code between the main power panel and sub panels.

FOR 15 AMP RATED LARGE MACHINES

For 0 to 30 Feet from panel to receptacle = Use 14 Ga. Wire.

For 30 to 50 Feet from panel to receptacle = Use 12 Ga. Wire.

For 50 to 80 Feet from panel to receptacle = Use 10 Ga. Wire.

For 80 to 140 Feet from panel to receptacle = Use 8 Ga. Wire.

For 0 to 15 Meters from panel to receptacle = Use 2.5mm Wire.

For 15 to 42 Meters from panel to receptacle = Use 4.0mm Wire.

FOR 220V 50 or 60Hz applications Product No. 6730951 should be ordered.

6730951 includes a 2 KVA 220 Volt Step Down to 110 volt 50/60 Hz transformer which is prewired.

The wiring diagram is shown in FIG. 13.

The power cord has no connector. A connector which is appropriate for your locality and 220 volt, 8 amp application should be installed.

USE ONLY A QUALIFIED ELECTRICIAN TO COMPLETE THE INSTALLATION.

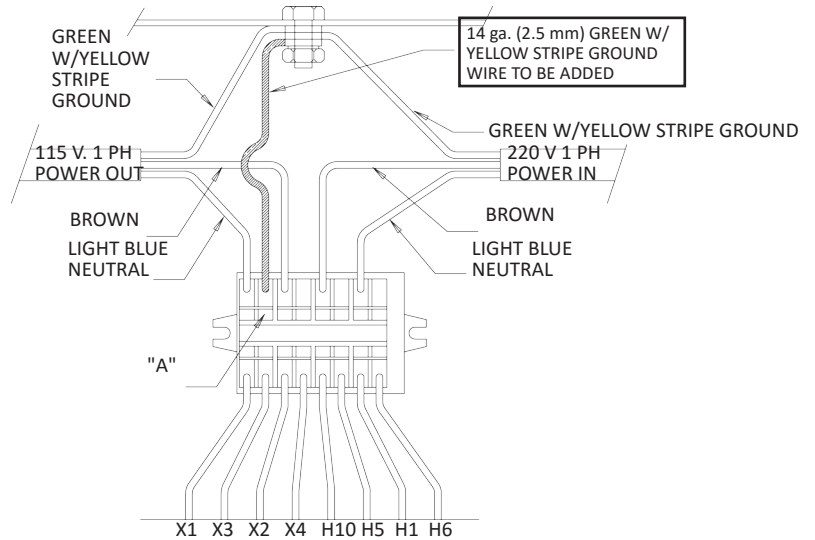

INDIVIDUALLY WIRE NUT TRANSFORMER LEADS H2, H3, H4, H7, H8, AND H9

INSTALL THE GREEN W/YELLOW STRIPE WIRE SUPPLIED INTO THE TERMINAL BLOCK IN THE HOLE OPPOSITE WIRE X3 AS SHOWN. TO INSTALL THE WIRE INSERT A SMALL SCREWDRIVER INTO THE CAVITY MARKED "A" TO OPEN THE WIRE HOLE.

ATTACH THE OTHER END OF THE GREEN W/YELLOW STRIPE WIRE SUPPLIED TO THE GROUND STUD ON THE TRANSFORMER

FIG. 13

IMPORTANT GROUNDING INSTRUCTIONS

In case of a malfunction of breakdown, grounding reduces the risk of electrical shock by providing a path of least resistance for electrical current.

This grinder has an electrical cord with an equipment grounding conductor and a grounding plug. The plug must be plugged into a matching outlet that is properly installed and grounded according to all local or other appropriate electrical codes and ordinances.

Before plugging in the grinder, make sure it will be connected to a supply circuit protected by a properly sized circuit breaker or fuse. SEE SERIAL NUMBER PLATE FOR FULL LOAD AMP RATING OF YOUR MACHINE.

Never modify the plug provided with the machine. If it won't fit the outlet, have a proper outlet and circuit installed by a qualified electrician.

ALWAYS PROVIDE A PROPER ELECTRICAL GROUND FOR YOUR MACHINE. AN IMPROPER CONNECTION CAN CAUSE A DANGEROUS ELECTRICAL SHOCK. IF YOU ARE UNSURE OF THE PROPER ELECTRICAL GROUNDING PROCEDURE, CONTACT A QUALIFIED ELECTRICIAN.



CHECK THE CARRIAGE TRAVERSE

Move the travel limit sensors to the ends of the slots. (See Figure 14).

Visually check that the grinding head will be able to traverse to both sides of the machine without contacting any components.

Turn all control panel switches OFF. Set the TRAVERSE FT/MIN knob to zero. Close the guard door and press START. Press CARRIAGE TRAVERSE to ON. Set TRAVERSE FT/MIN to a low speed, and check that the grinding head runs through a complete traverse cycle. Be prepared to press STOP if there is any interference. Watch carefully for obstructions to the head travel, and check that the grinding motor cord and proximity switch cords are not stretched.

NOTE: If the unit doesn't begin a traverse cycle, check the 15 amp circuit breaker inside the control box.

CHECK THE GRINDING MOTOR

Turn all control panel switches OFF. Close the guard door to connect the interlock. Press START. Press Grinding Motor Switch to ON. Check that the grinding head runs properly. Be prepared to press STOP if there is any problem.

NOTE: If the grinding head doesn't begin properly, check the 15 amp circuit breaker inside the control box.

MAKE FINAL PREPARATIONS FOR OPERATION

Carefully read the operating instructions in the Operator's Manual.

First, study the pages titled "Getting to Know Your Grinder" and "General Operating Information" for important background explanations about the machine and about bedknife grinding.

Then, read the "Operating Instructions" pages for step-by-step procedures on mounting the bedknife and grinding its top and front faces.

CHARGING THE UNINTERRUPTED POWER SUPPLY

This machine is equipped with a battery backup for the Electromagnets. The battery will need to be charged for a minimum of 24 hours before using the equipment. The battery will be charged if the machine is plugged in. To test the battery backup, unplug the machine and turn on the electromagnets. Use a screw driver or piece of steel to verify that the magnets are working.



THE UPS WILL NOT FUNCTION PROPERLY IF THERE IS INSUFFICIENT POWER TO THE MACHINE. INSUFFICIENT POWER MAY ALLOW THE BEDKNIFE TO SLIP OR MOVE ON THE MAGNETS WHILE GRINDING. SEE PREVIOUS PAGE FOR POWER REQUIREMENTS.



THE UNINTERRUPTABLE POWER SUPPLY (UPS) WHICH IS USED AS A BACKUP TO HOLD THE BEDKNIFE TO THE ELECTROMAGNETS DURING A POWER INTERRUPTION HAS A BATTERY. THIS UPS HAS A THREE TO FOUR YEAR LIFE EXPECTANCY AND MUST BE REPLACED AFTER THREE TO FOUR YEARS OF SERVICE LIFE. SEE THE PARTS LIST FOR REPLACEMENT UPS PART NUMBER.

CONTROL BOX

The control box contains the electrical controls for the grinder.

GRINDING HEAD

The grinding head consists of the grinding wheel and safety guard, and the motor which drives the wheel.

DRIVE CARRIAGE AND VERTICAL ADJUSTER

The carriage and vertical adjuster provide a movable support for the grinding head. A handwheel adjusts the grinding wheel position forward and back. An eccentric cam and lock mechanism adjusts the grinding wheel position up and down.

TRAVERSE MOTOR AND DRIVE BELT

A drive belt traverses the carriage from side to side to move the grinding wheel along the bedknife. The belt is driven by a motor on the left end of the machine.

BEDKNIFE SUPPORTS

Two electromagnet assemblies support the bedknife for grinding. A fixed electromagnet on the left end, and an adjustable electromagnet on the right end.

TOOLING ROTATION

The tooling assembly rotates to allow the grinder to grind both the top face and front face of the bedknife.

TRAVEL LIMIT SENSORS

The bedknife grinder has travel limit sensors to stop the carriage travel and reverse its direction. They are adjustable by sliding the sensors along a long slot in the rail.

COOLANT TANK

A large tank along the back of the grinder.

TRAVEL MECHANISM RELEASE

To move the grinding head from side to side manually, there is a release located on the front of the carriage. To disengage the carriage drive system, rotate the red handle engagement lever to the right. To engage the carriage drive system, rotate the red handle engagement lever to the left until it locks.

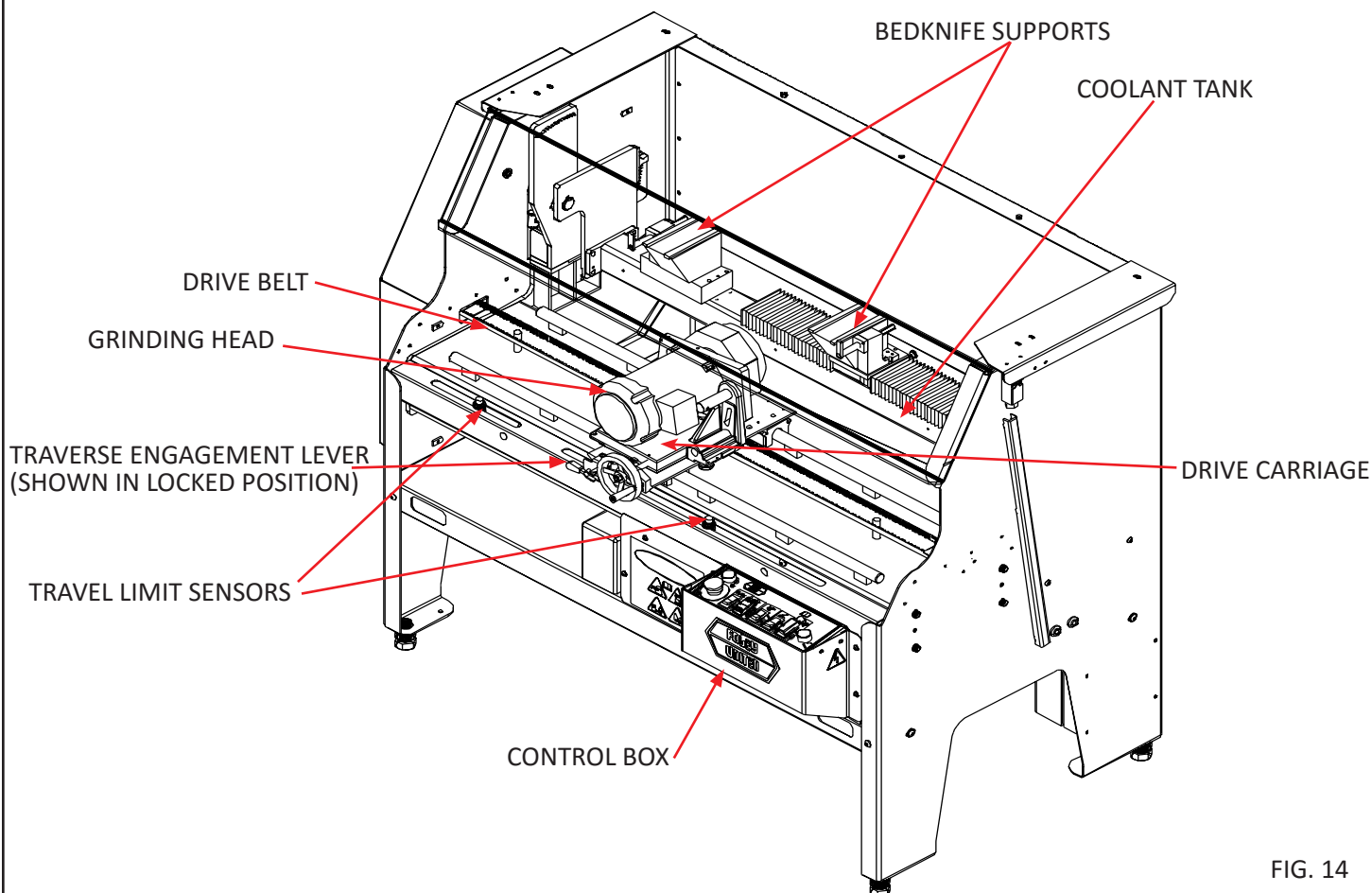

FIG. 14

CONTROL PANEL

RESET BUTTON (GREEN)

Resets the controls after the Emergency Stop Switch has been pressed. The Grinding Motor Switch must be in the OFF position or the Reset Button will not reset.



IF THE TRAVERSE SWITCH OR THE COOLANT PUMP SWITCH IS IN THE ON POSITION, THEIR FUNCTIONS WILL IMMEDIATELY START WHEN THE RESET BUTTON IS PRESSED.

EMERGENCY STOP BUTTON

Shuts down power to the grinder **with the exception of the electromagnets**. **NOTE: the EMERGENCY STOP BUTTON must be pulled up for the RESET BUTTON to engage.** The RESET and STOP buttons control the main power to the grinder, **except the electromagnets which are independently powered**. Use the other switches to control the separate operating functions.



FOR SAFETY, THE EMERGENCY STOP SHUTS DOWN THE MACHINE AND SHUTS OFF ALL SWITCHES EXCEPT FOR THE ELECTROMAGNET SWITCH. TO START THE GRINDER, PULL OUT THE EMERGENCY STOP BUTTON AND PRESS THE RESET BUTTON.

EMERGENCY STOP BUTTON AND PRESS THE RESET BUTTON.

TRAVERSE SPEED KNOB

Controls the travel speed of the carriage and grinding head. The scale is in feet/minute.

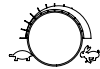

INFEED/OUTFEED SWITCH

Depress the rocker switch in the UP direction to infeed the grinder head. Depress the rocker switch in the DOWN direction to outfeed the grinder head. The motor will move .001" (.02mm) with each press. Holding the button for more than 1/2 seconds will start a slow constant movement. Holding the button for more than 2 seconds will cause the grinding head to move at a higher speed.

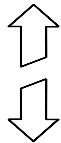

CARRIAGE TRAVERSE SWITCH (ON/OFF)

Activates the drive belt to traverse the carriage.

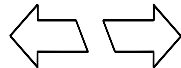

TOOLING POSITION SWITCH (MOMENTARY)

Pushing UP causes the tooling to rotate up to the preset top face stop. Pushing DOWN causes the tooling to rotate to the preset front face stop.

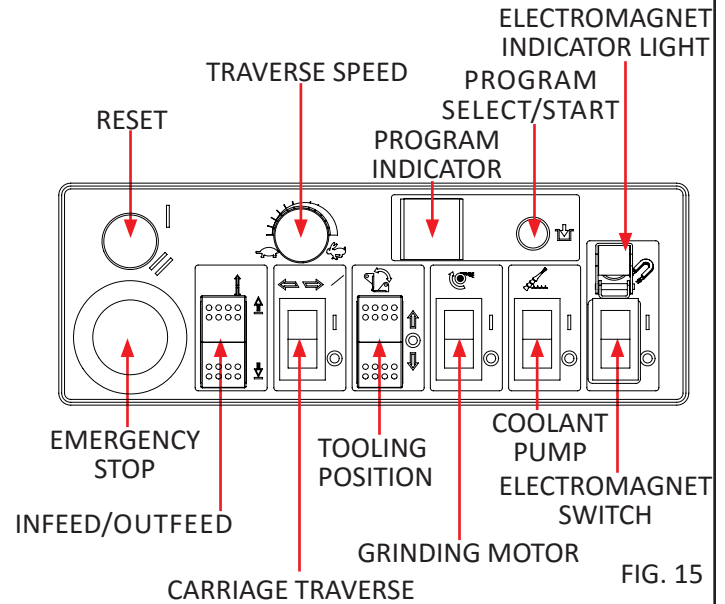
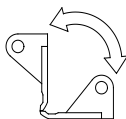
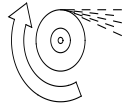

FIG. 15

GRINDING MOTOR SWITCH (ON/OFF)

Controls electrical power to the grinding head motor. This switch will function only when the door is closed.



COOLANT PUMP SWITCH (ON/OFF)

Controls electrical power to the flood coolant pump.

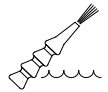

ELECTROMAGNET SWITCH and LIGHT (ON/OFF)

Controls electrical power to the electromagnets for holding the bedknife and bedbar. **This switch is independent from the start and stop switches and is powered through the standby power supply.** A green light indicates the power is on.

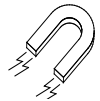

THE ELECTROMAGNETS SHOULD BE ON ONLY WHEN GRINDING A BEDKNIFE. NEVER KEEP THE ELECTROMAGNETS ON FOR MORE THAN ONE HOUR OR DAMAGE TO THE ELECTROMAGNETS MAY OCCUR.

PROGRAM SELECT/START BUTTON

Press this button to select from the list of preset grinding programs. The number of the program will appear on the Program Indicator LED screen. The program will automatically run the selected program after a 2 second delay. Pressing the button while a program is running, will cancel the program. If the program is cancelled, the grinding head will continue grinding until it returns to the right travel limit sensor position.

NOTE: A program can not be selected and the auto mode will not function unless the right travel limit sensor is activated when pressing the the Program select and start button. If there is an error when selecting a program an "E" will be displayed.

TOOLING ROTATION

To achieve desired grinding angles, the bedknife grinder has a movable tooling bar with calibrated stops. Figure 16 shows the upper or top face stop and the lower or front face stop. The tooling bar is moved from stop to stop by pressing the tooling position switch.

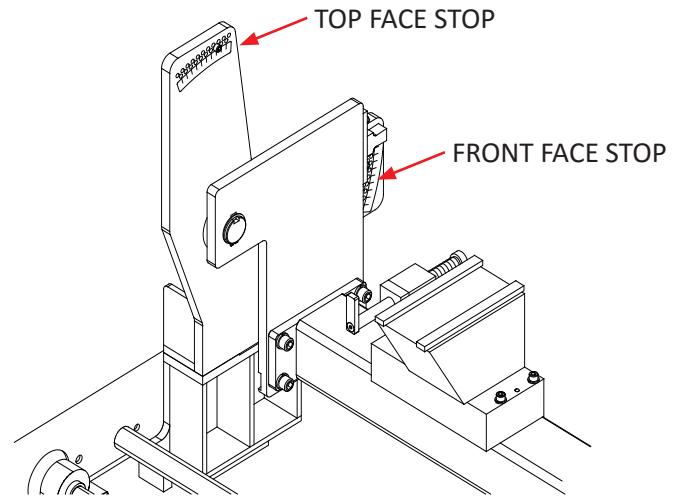
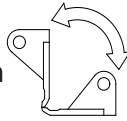

FIG. 16

FIXED ELECTROMAGNET SUPPORT (FIG. 17)

The bedknife and bedbar are held in position by two electromagnets. The left side electromagnet position is fixed.

ADJUSTABLE ELECTROMAGNET SUPPORT (FIG. 17)

The right side electromagnet is adjustable to match bedknife width.

Electromagnet Lock Knob

Locks the right electromagnet assembly in position.

RIGHT HAND TOOLING ALIGNMENT ADJUSTER (FIG. 18)

Adjustment Handwheel

Allows the tooling assembly to be adjusted out of parallel position to gain maximum life from used bedknives.

Zeroing Dial Indicator

Indicates the location of the right side tooling adjuster to the factory set zero position. To reset the right side tooling adjustment, turn the tooling adjustment handwheel until the dial indicator reads .500" .

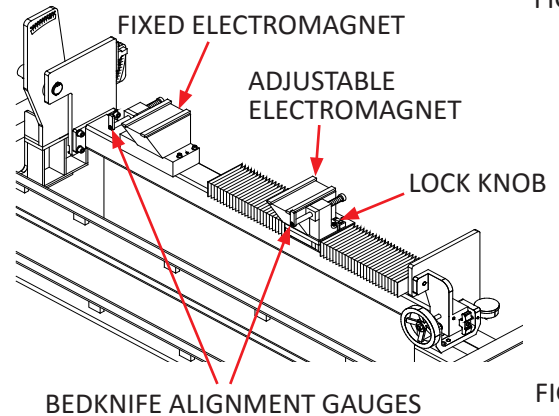

FIG. 17

BEDKNIFE ALIGNMENT GAUGE (FIG. 17)

On the outside of each electromagnet is a retractable bedknife alignment gauge. These gauges are used to align the bedknife to the grinding wheel carriage travel.

UNINTERRUPTABLE POWER SUPPLY (FIG. 19)

The UPS supplies back-up power to the electromagnets, holding the bedknife in position during a loss of power. An audible alarm indicates that the battery power is low. If power is not reapplied to the machine, the control will interrupt the battery power. This will turn off the electromagnets to protect the battery from damage.

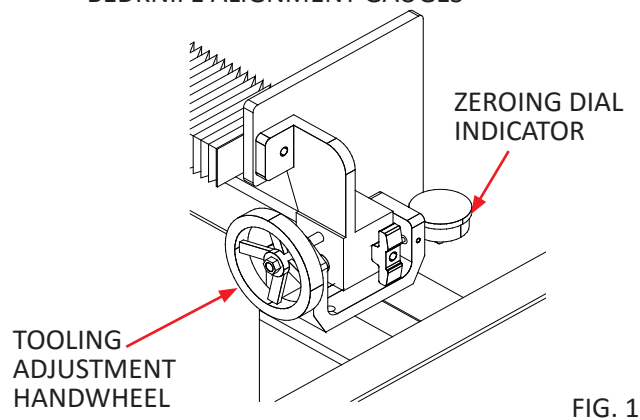

FIG. 18



FOR SAFETY, IF THE POWER IS INTERRUPTED, THE OPERATOR SHOULD REMOVE THE BEDKNIFE WITHIN 3-5 MINUTES.

LOW BATTERY ALARM (INSIDE CONTROL)

UPS BATTERY (INSIDE CONTROL)

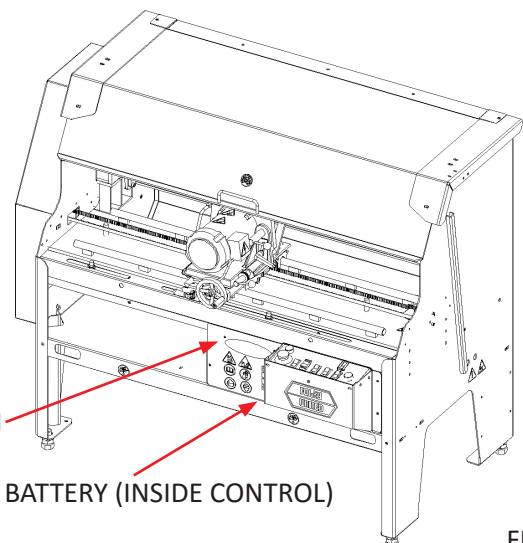

FIG. 19

GRINDING HEAD (FIG. 20)

Vertical Eccentric Adjuster and Lock

Moves the grinding head up and down.

Infeed Handwheel

Manually moves the grinding head in and out.

Stepper Infeed Motor

Automatically infeeds the grinding wheel during the grinding process. This motor is also controlled by the infeed/outfeed switch on the control.

Wheel Guard Lock Screws

A T-knob holds the guard in position. Loosen it to rotate the guard when the guard interferes with the bedbar.

Diamond Wheel Dresser

Use to dress the grinding wheel. Cleaning and dressing the grinding wheel improves the quality of the grind.

Coolant Nozzle

Directs a stream of coolant onto the bedknife and grinding wheel. The flexible nozzle can be adjusted for proper placement.

Coolant Flow Valve

Controls the volume of coolant flowing to the nozzle. Use only enough flow to cool the bedknife. Excess flow will cause excess splashing - and **will not** improve performance.

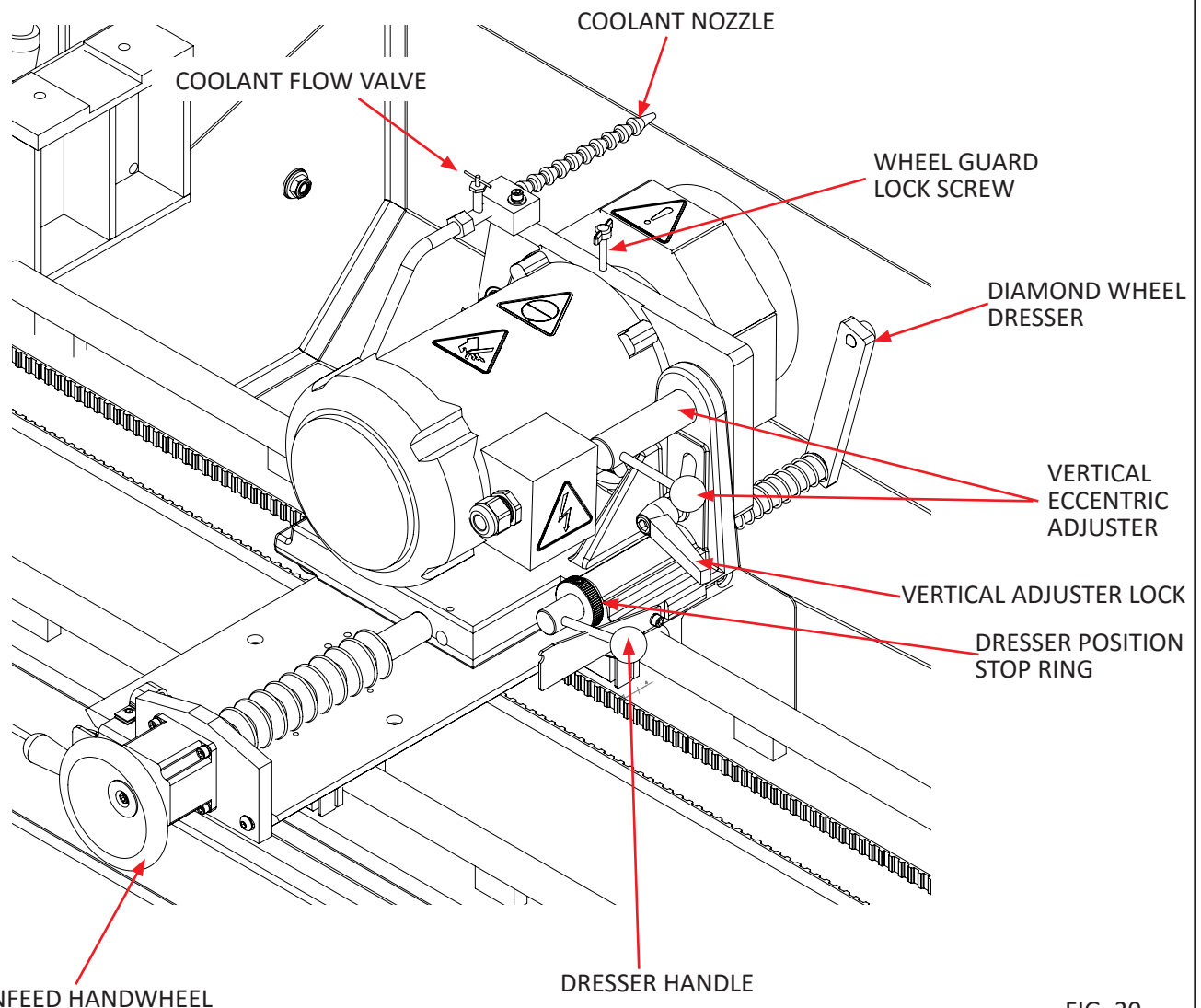

FIG. 20

REPLACING THE WHEEL

A new vitrified grinding wheel is 2" [51 mm] deep. When it wears down to a depth of 0.75" [19 mm], it should be replaced. See FIG. 21.

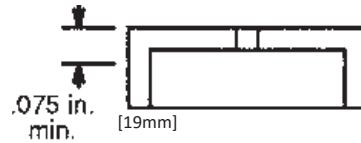

FIG. 21

MOUNTING A GRINDING WHEEL

To replace the grinding wheel:

1. Unplug the machine.
2. Unscrew the mounting flange that holds the grinding wheel, using the special wrench provided. **NOTE: The flange has left hand thread.**
3. Remove the old wheel and install the new one.
4. Screw on the flange finger tight, then tighten approximately 1/8 turn further with the wrench. It will self-tighten when the motor is turned on.



IF THE WHEEL FLANGE IS OVERTIGHTENED, THE GRINDING WHEEL MAY CRACK AND FLY APART.

5. After you install a new or different wheel, it is recommended that you dress the wheel before grinding. Dressing trues the grinding surface of the wheel and removes the hard glaze produced during the manufacturing process. This dressing properly prepares the wheel for grinding. See Page 22.

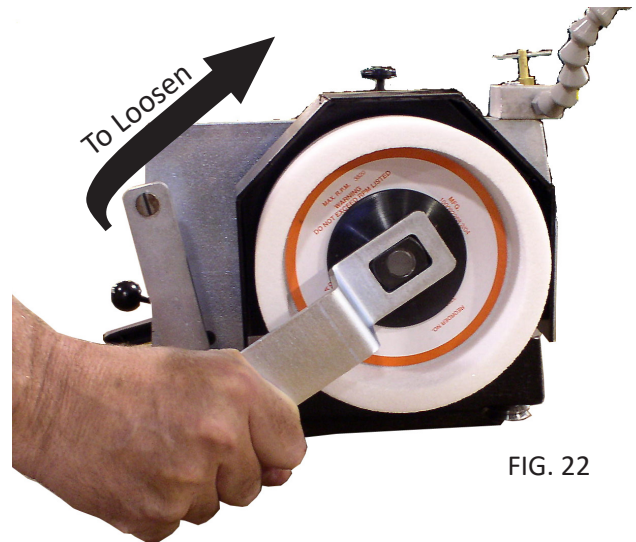

FIG. 22

GRINDING WHEELS AVAILABLE FOR 673 BEDKNIFE GRINDER		
WHEEL PART NO.	COLOR DESCRIPTION	SIZE/GRIT
3700060	White/red flare-cup wheel, 6/3-1/4 x 2 x 0.627 inch bore, vitrified ruby	60
3700062	White flare cup wheel, 6/3-1/4 x 2 x 0.627 inch bore, vitrified	45
3700268	White/red straight-cup wheel, 6 x 2 x 0.627 inch bore, vitrified ruby	60
3700411	White straight-cup wheel 6 x 2 x 1.25 inch bore, vitrified	46 STANDARD
3700696	Borazon straight-cup wheel, 6 x 1-1/2 x 0.625 inch bore	120 For normal or extra hardened bedknife

ROTATING THE WHEEL GUARD

When grinding bedknives and bedbars with mounting ears located close to the bedknife top face, the wheel guard may contact the bedknife. For these bedknives, loosen and rotate the grinding wheel guard so the clearance area of the guard allows the bedknife to be ground without the guard contacting the bedknife. When you are finished, **ALWAYS** reposition the guard to its normal position with the clearance notch down. See FIG. 23.

If the end mounting flanges of the bedknife are more than 2" [50 mm] high or near the front face of the knife, you may need the optional 6" flared cup wheel.

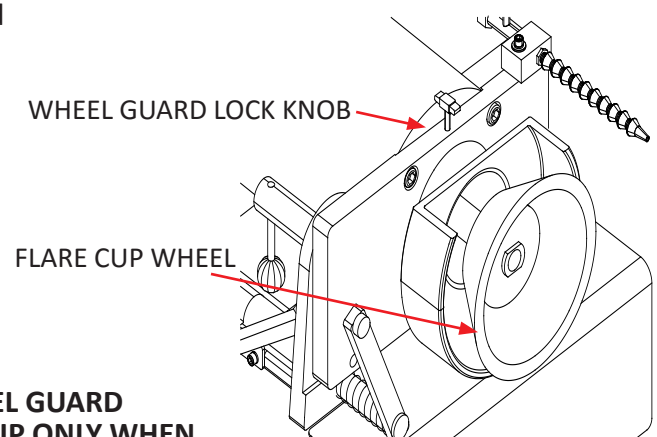

FIG. 23



FOR OPERATOR SAFETY, THE GRINDING WHEEL GUARD MUST BE USED WITH THE CLEARANCE AREA UP ONLY WHEN REQUIRED FOR BEDBAR CLEARANCE.

DRESSING THE GRINDING WHEEL

Dress the grinding wheel whenever there is glazing. Glazing is the buildup of stone dust, grinding grit, and coolant on the face of the wheel. Also, for best results, dress the wheel before making the final grind.



REFER TO THE "SAFETY RULES WHEN GRINDING" ON PAGE 3.

Before dressing, always move the grinding head to the right hand side of the machine, as shown in FIG. 24, so the grinding head is clear of the bedknife.

1. Lift the dresser movement arm off its lock bracket by pulling it back towards you and rotating the arm counter-clockwise. Allow the dresser to travel forward until it reaches the position stop ring.
2. Swing the dresser about 15 degrees clockwise to position the diamond point in front of the grinding face of the wheel. See FIG. 26. Rotate the position stop ring until the diamond point of the dresser lightly contacts the face of the wheel. See FIG. 26.

NOTE: *It is important to adjust the position stop ring when using the dresser for the first time and after installing a new wheel. After initial setup steps 2 and 3 may be skipped.*

3. Rotate the dresser arm back to the starting position (Clockwise) so that the diamond is to the right of the grinding wheel.
4. Rotate the position stop ring clockwise 15-30 degrees to infeed the diamond point.
5. Turn the grinding motor ON.
6. Rotate the handle at a medium pace so the diamond goes over the wheel counter-clockwise and then rotate it back clockwise. The wheel is now dressed, you only need to run the diamond back and forth once. Any additional passes will actually decrease the performance of the wheel.
7. When completed, rotate the handle clockwise against the lock bracket before pulling back and placing the dresser movement arm in the lock bracket. See FIG. 25.

NOTE: *Excessive dressing will shorten the life of the wheel and may cause the diamond to dislodge from the dresser tip, while insufficient dressing will inhibit proper grinding.*

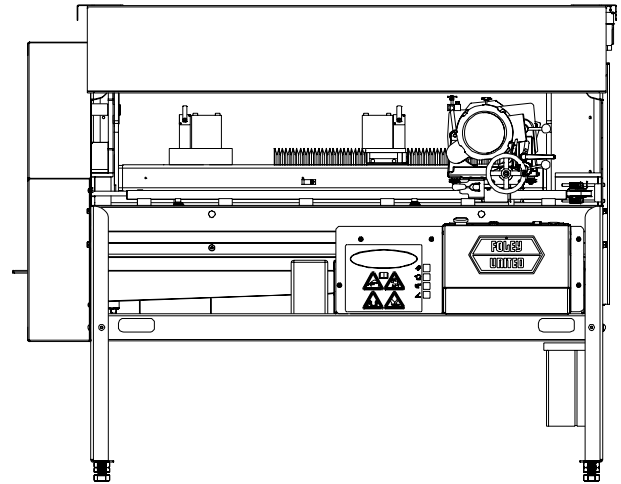

FIG. 24

DRESSER IN LOCKED POSITION

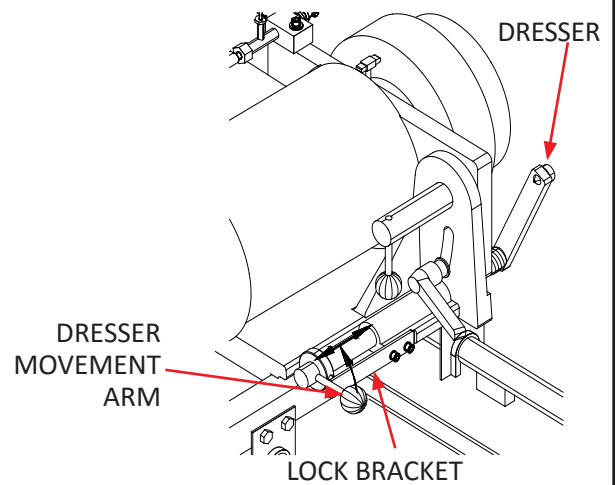

FIG. 25

DRESSER UNLOCKED & READY TO USE

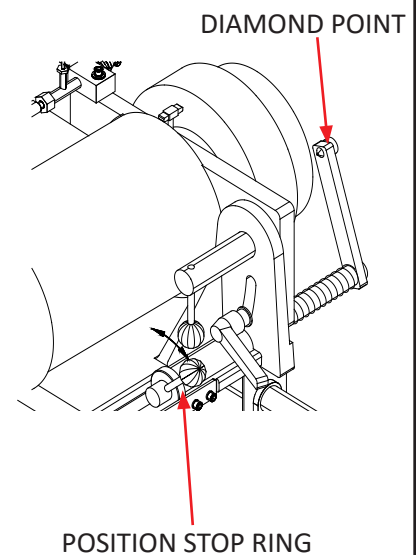

FIG. 26

! MIXING AND ADDING THE COOLANT THE COOLANT RATIO AS SPECIFIED MUST BE USED. TOO HIGH A CONCENTRATION OR TOO LOW A CONCENTRATION WILL CAUSE CORROSION AND PERFORMANCE PROBLEMS.

Be sure the COOLANT PUMP switch is OFF. Mix (Part No. 3708620) coolant in the coolant tank, at a ratio of 50 parts water to 1 part concentrate. This will take about 4.5 gallons of water and .75 pints of concentrate (17 liters of water and 0.35 liter of concentrate).

Refer also to the label on the coolant container.

Pour the coolant into the coolant tank until the coolant level in the main tank is 1/4-1/2" [6-12 mm] above the top edge of the sump.

CHECK THE COOLANT PUMP

Turn all control panel switches OFF. Close the guard door and press the RESET button. Press the COOLANT PUMP SWITCH to ON. Check that the coolant system is functioning properly. Be prepared to press STOP if there are any problem.

NOTE: If the unit doesn't begin to pump coolant, check the coolant pump circuit breaker on the control panel to see if it has tripped. If tripped, push in to reset. See FIG. 28.

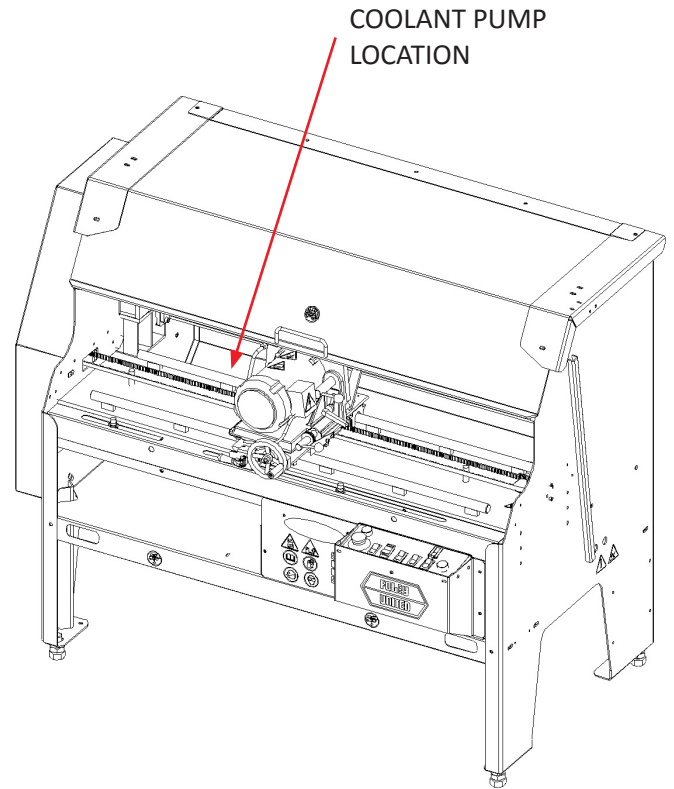

FIG. 27

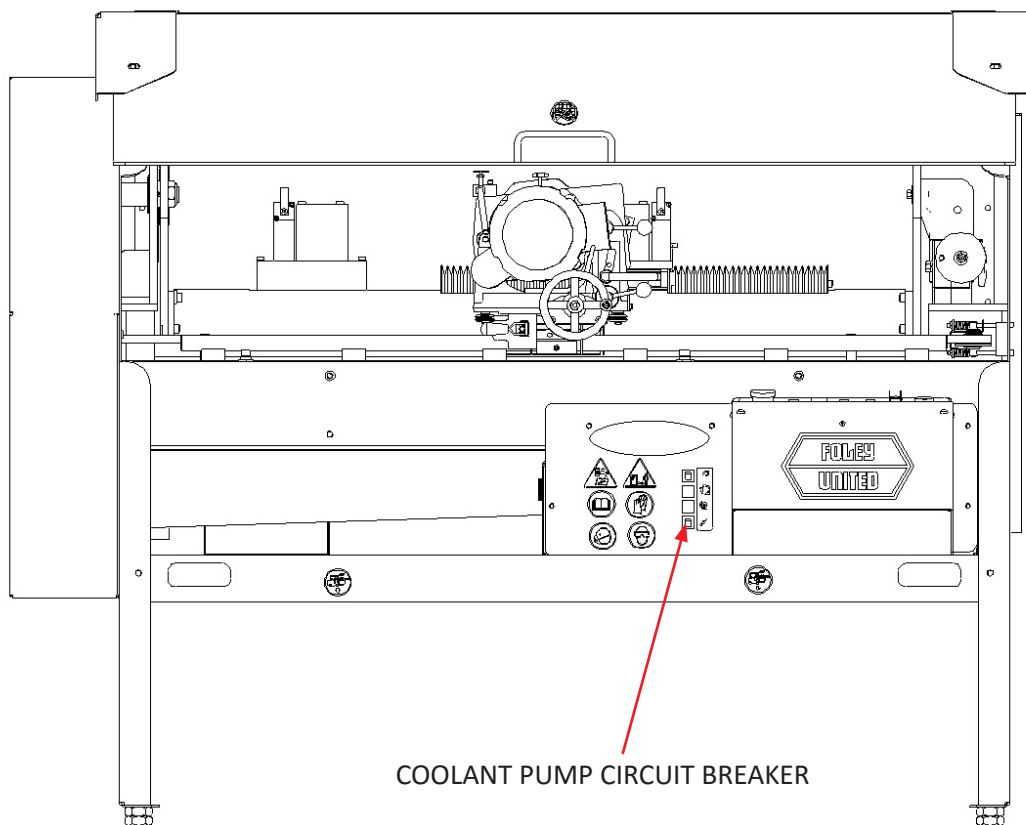

FIG. 28

USING FLOOD COOLANT

For quality grinding, we highly recommend using flood coolant to prevent heat buildup on the knife edge.



IF YOU DO DRY-GRIND, NEVER ALLOW THE BEDKNIFE EDGE TO CHANGE COLOR OR YOU MAY LOSE THE TEMPER IN THE KNIFE EDGE.

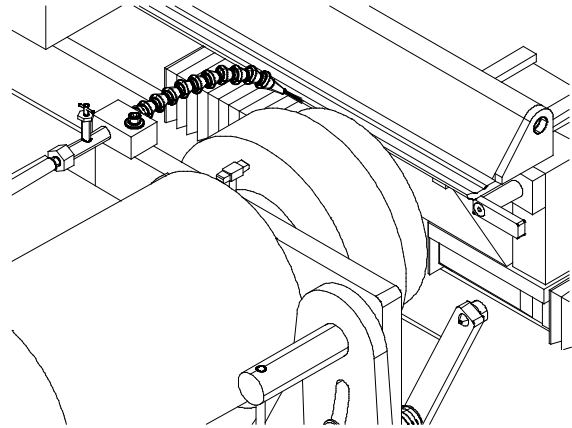

FIG. 29

ALWAYS READ THE MATERIAL SAFETY DATA SHEET (MSDS) FOR THE COOLANT YOU ARE USING. BELOW ARE WARNINGS THAT APPLY TO MOST COOLANTS.

AVOID CONTACT OF COOLANT WITH EYES: IT WILL CAUSE EYE IRRITATION. WEAR FACE SHIELD OR GOGGLES WHEN HANDLING CONCENTRATE. IN CASE OF CONTACT, FLUSH EYES WITH WATER FOR 15 MINUTES AND CONTACT A PHYSICIAN.



AVOID BREATHING MISTS. PROVIDE LOCAL VENTILATION. KEEP CONCENTRATED BOTTLE CLOSED WHEN NOT IN USE. CONTINUED CONTACT OF CONCENTRATE ON SKIN MAY CAUSE IRRITATION. WASH WITH SOAP AND WATER AFTER CONTACT.

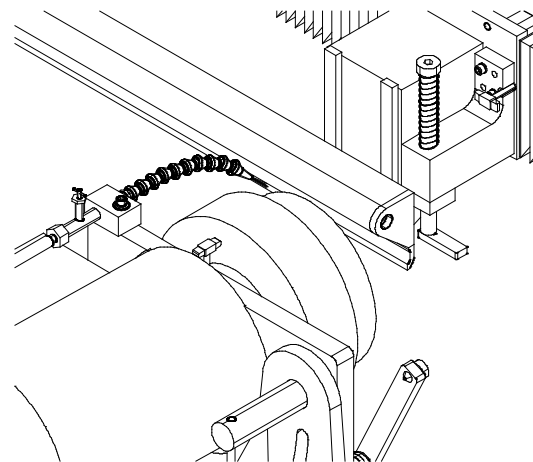

FIG. 30

DO NOT TAKE INTERNALLY. IF INGESTED, CONSULT PHYSICIAN AND DO NOT INDUCE VOMITING.

(HAZARD POTENTIAL APPLIES TO CONCENTRATE, AND IS LESS AT NORMAL USE DILUTION.)



THE COOLANT RATIO AS SPECIFIED MUST BE USED. TOO HIGH A CONCENTRATION OR TOO LOW A CONCENTRATION WILL CAUSE CORROSION AND PERFORMANCE PROBLEMS.

Using the Coolant

Direct the nozzle so the coolant flows onto the bedknife face being ground. See FIG. 29 or 30. Some coolant will also be deflected onto the grinding wheel. Adjust the flow valve so there is a steady stream of coolant. Avoid a stronger flow than needed as excessive coolant doesn't provide any additional cooling, but does increase splashing.

Fluid Level in Coolant Tank

Check the fluid level in the coolant tank daily to avoid running out while grinding. Keep the coolant .25 - .50 inches [6-12 mm] above the top of the coolant sump. **The pump must always be completely submerged in water.** Never add plain water to the coolant when the level is low. Always add water and concentrate in the correct proportions. It is recommended to pre-mix coolant and water in a separate container for this purpose.

BEDKNIFE GRINDING ANGLES

The bedknife has two faces that normally need to be ground - the top face and the front face (on some models, the front face may be curved and therefore may not require sharpening.)

The proper grinding angles for the two faces will vary, depending on the reel manufacturer. **Always follow the manufacturer's recommended specifications for bedknife angles.**

Set the Bedknife Angles

1. From the mowing unit manual or from the mowing unit manufacturer, determine what the correct top face angle and front face angle is for your bedknife.
2. Move the tooling ROTATION ACTUATOR so the tooling bar stop is at midpoint between the front face stop and the top face stop.
3. Move the TOOLING ROTATION STOP PIN for the front face to the correct angle. See FIG. 32.
4. Move the TOOLING ROTATION STOP PIN for the top face to the correct angle. See FIG. 32.

Prepare the Machine for Mounting the Bedknife

Pivot the tooling assembly to the horizontal position (Front face grinding position). Move the grinding head all the way to the right, then outfeed the grinding head away from the tooling bar

NOTE: Always wipe any grindings, dirt, etc. from the electromagnets before mounting the bedknife.

MOUNTING A BEDKNIFE FOR GRINDING

Inspect and Clean the Bedknife

Inspect the bedknife for damage (cracks, warping, bushing wear, excessive bedknife wear). Replace or repair if necessary (see the mowing unit manufacturer's manual). Thoroughly clean the bedknife, especially on the bottom where the electromagnets will attach. **It is recommended to thoroughly wire brush these areas.**

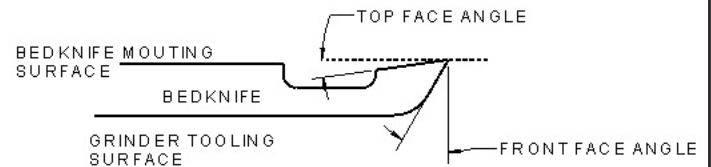

FIG. 31

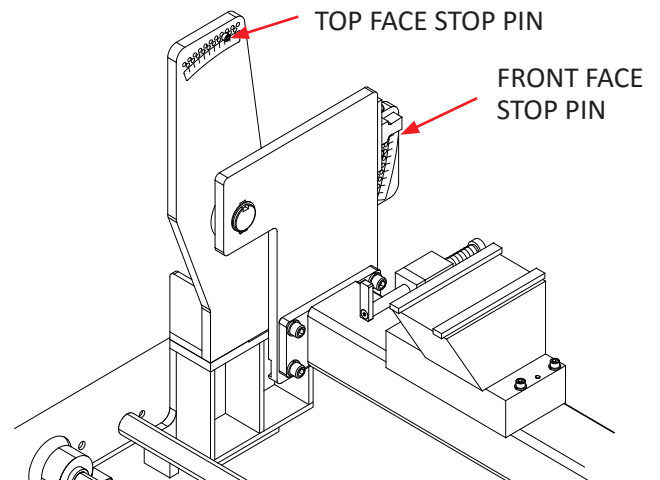

FIG. 32

MOUNTING A BEDKNIFE FOR GRINDING (Continued)

Mount the Bedknife

1. Pull both bedknife alignment gauges forward and rotate to lock into position. Loosen the knob on the right side electromagnet assembly. See FIG. 33. Set the bedknife / bedbar assembly to be ground on the electromagnets. Move the right side electromagnet assembly until the alignment gauge tips are at both ends of the bedknife. See FIG. 36. Tighten the right side electromagnet lock knob enough to secure the electromagnet assembly.
2. Check the right side adjustment assembly. The dial indicator should read .500. If not, loosen the lock knob and adjust the handwheel until the dial indicator reads .500 and tighten the lock knob. See FIG. 34.
3. Position the bedknife so the unworn tips on a used bedknife or the ends of a new bedknife are against the alignment gauge tips. See FIG. 35. Pull the bedknife forward firmly against the gauge tip and then turn the electromagnet switch to ON. See FIG. 36.

! THE ELECTROMAGNETS SHOULD BE ON ONLY WHEN GRINDING A BEDKNIFE. NEVER KEEP THE ELECTROMAGNETS ON FOR MORE THAN ONE HOUR AS DAMAGE TO THE ELECTROMAGNETS CAN OCCUR.

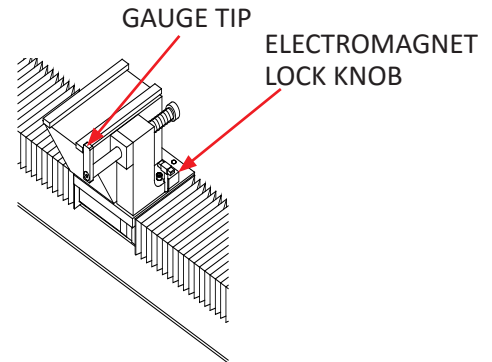

FIG. 33

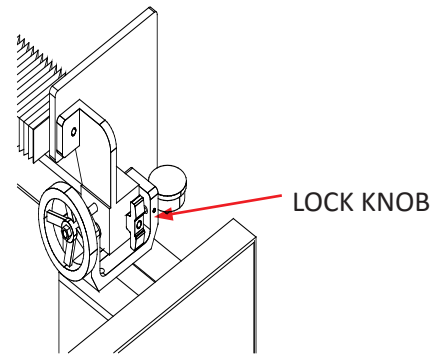

FIG. 34

BEDKNIVES WITH DUAL CUTTING EDGES

Some mowing unit manufacturers and some aftermarket bedknife manufacturers make a bedknife with Dual Cutting Edges as shown in FIG. 37.

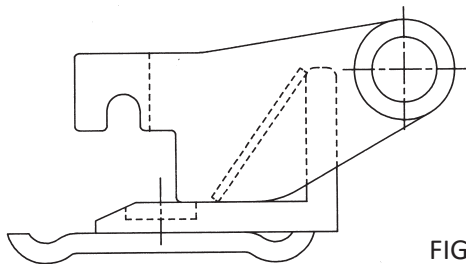

FIG. 37

The two rounded surfaces on the bottom of the bedknife provide too small of a surface area for the electromagnets, limiting the holding force of the electromagnets. File the bottom side of the bedknife with a flat bastard file as shown in FIG. 38 to increase the surface area. File with a uniform stroke across both radii until you have developed a flat on each radius that is a minimum of 3/32(.09) [2.3mm] wide. The flat spots should be uniform in width for the length of the magnet on each end of the bedknife.

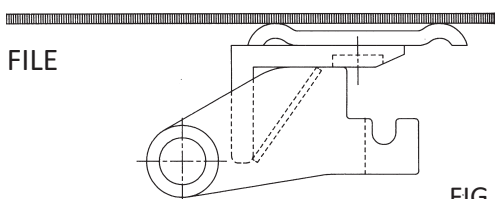

FIG. 38

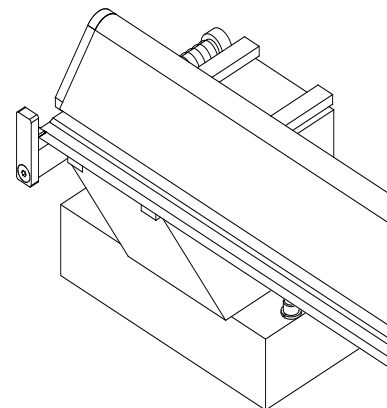

FIG. 35

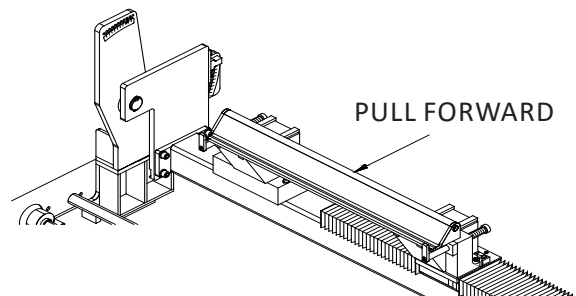

FIG. 36

MACHINE SETUP

NOTE: *On some mower bedknives, the front face is curved and therefore may not require sharpening.*

Position the Head for Front-Face Grinding (See FIG. 39)

Use the stop pins to set the front face angle and top face angle stops. Use the Tooling Position Switch to rotate the tooling assembly to the horizontal front face position (down).

Check for Clearance and Set Traverse Travel Limit Sensors

Position the grinding head so that the grinding wheel just touches the front face of the bedknife. Use the vertical cam and lock lever to adjust the grinding head so the grinding wheel rim extends a minimum of 1/2" [12mm] above the front face to be ground. See FIG. 40.

! IF THE GRINDING WHEEL RIM DOES NOT EXTEND OVER THE BEDKNIFE FACE, IT WILL WEAR UNEVENLY AND CAUSE GROOVES ACROSS THE SURFACE OF THE BEDKNIFE.

NOTE: *The left side of the wheel does the grinding. When grinding the left end of the bedknife, the right side of the wheel can remain over the bedknife surface. However, when the carriage traverses to the right end of the bedknife, the wheel must come completely off the bedknife.*

1. Outfeed the grinding head so the wheel no longer touches the front face of the bedknife.
2. Slide the left and right travel limit sensors to the far ends of the slot.
3. Set the traverse knob to 10. Set the carriage traverse switch to ON. Traverse the carriage to the left until the contact area of the grinding wheel is about 1" beyond the area to be ground on the bedknife, and then turn the traverse knob to ZERO. Be prepared to STOP the traverse earlier if there is any interference between the grinding wheel and the bedknife/bedbar. See FIG. 41.
4. With the carriage still in the position determined in Step 3 above, slide the left travel limit sensor in until the LED on the base of the sensor illuminates.
5. Turn the traverse knob to 10 and traverse to the right until the grinding wheel reaches the right end of the bedknife and goes past that point by 1" [25 mm]. Then move the right travel limit

sensor in until the LED light at the base of the sensor illuminates.

6. Infeed the grinding wheel until it very lightly touches the bedknife. Next, traverse the length of the bedknife to assure that there is sufficient clearance between the grinding wheel and the bedknife. Use the outfeed switch to back the wheel out if necessary until you can traverse the full length with only a very light touch at the closest point.

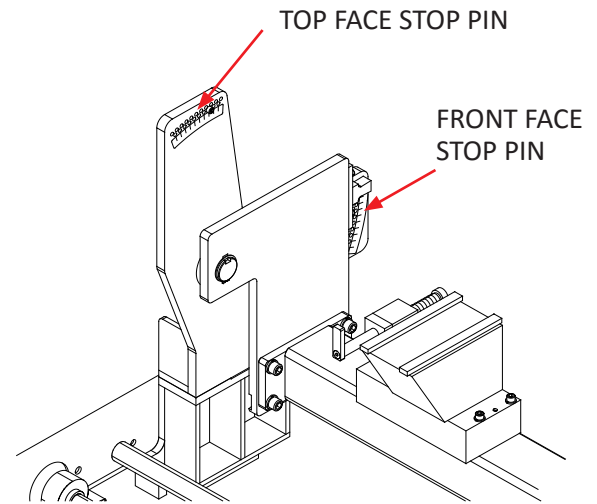

FIG. 39

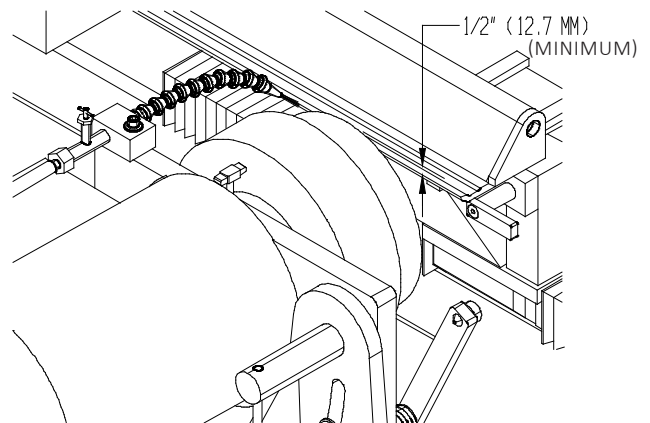

FIG. 40

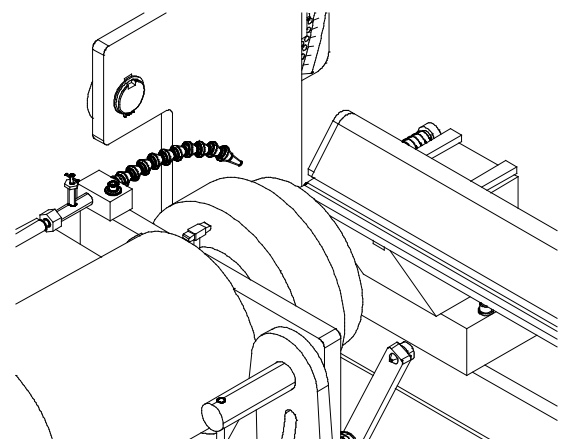

FIG. 41

GRINDING THE FRONT FACE (Continued)

Grinding the Bedknife

When you are satisfied with the grinder head travel, you are ready to begin grinding.



REFER TO THE "SAFETY RULES WHEN GRINDING" ON PAGES 8 & 9.

1. Close the guard door.
2. Set the traverse speed knob to 15.
3. Traverse the grinding head carriage and stop to the right travel limit sensor. The LED light on the base of the sensor must be illuminated.
4. Use the program selector button to cycle through the available programs. Stop at the desired program. After a short pause, the machine will start all necessary motors and begin the selected grind program.
5. If the grind is too light or too heavy you may press the infeed/outfeed switch during the program to move the grinding head IN or OUT .001" [.02 mm] per press.
6. Continue grinding the bedknife in this manner until you are satisfied with the front face grind. Dress the wheel when necessary (see "Dressing the Grinding Wheel" on Page 22).

NOTE: During the grinding process, watch the spark pattern for the full length of grind. The sparks should look equal for the full length of grind.

At the end of the program the machine will shut off all motors and the light on the front of the control will flash.

NOTE: You can stop the grinding program at any time by pressing the program selector button. When interrupted, the grinding head will finish its current traverse cycle and turn itself off when it reaches the right travel limit sensor.

By partially grinding both surfaces, the top face and the front face, as shown in FIG. 43, you will sharpen a used bedknife with the least metal removal. Partially grinding both surfaces is the preferred method for maximizing the life of the bedknife.

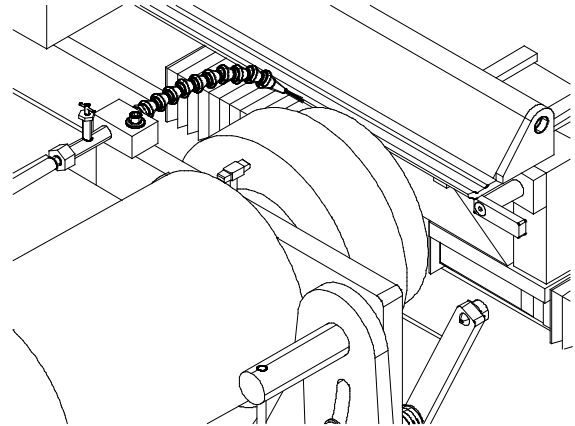

FIG. 42

PRESET PROGRAM LIST

LED NO.	INFEED AMOUNT	NO. OF PASSES	SPARKOUT PASSES
0	No Program Selected		
1	.004 [.1mm]	4	7
2	.008 [.2mm]	8	7
3	.012 [.3mm]	12	7
4	.016 [.4mm]	16	7
5	.020 [.5mm]	20	7



FIG. 43

GRINDING THE TOP FACE

Position the Head for Top-Face Grinding (See FIG. 44)

Before rotating the tooling assembly from front face grinding to top face grinding, the grinding head must be backed out by using the outfeed button or by turning the manual handwheel at least two full turns. If you have not preset the top face angle, do so at this time. Use the tooling position switch to rotate the tooling assembly to the top face position (up).

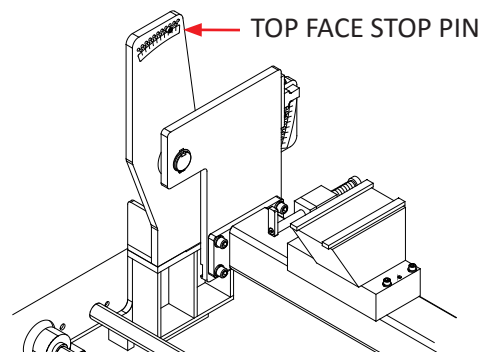

FIG. 44

BECAUSE ELECTROMAGNETIC ENERGY IS HOLDING THE BEDKNIFE IN THIS VERTICAL POSITION. DO NOT LEAVE THE BEDKNIFE IN THIS POSITION FOR EXTENDED PERIODS OF TIME. IF POWER IS LOST, THE STANDBY POWER SUPPLY WILL HOLD THE BEDKNIFE FOR APPROXIMATELY 5 MINUTES, BEFORE ALLOWING THE BEDKNIFE TO FALL.

Check Clearances and Set Traverse Limits

Position the grinding head so that the grinding wheel **just** touches the top face of the bedknife. Check to see if the rim of the grinding wheel is extended 1/2" [50mm] above the top face of the grinding wheel. If you have previously ground the front face it most often will be correct. If not, use the vertical cam and lock lever to adjust the grinding head. See FIG. 45. If the shape of the bedbar contacts the wheel guard or grinding wheel you will need to make adjustments (see Page 21).

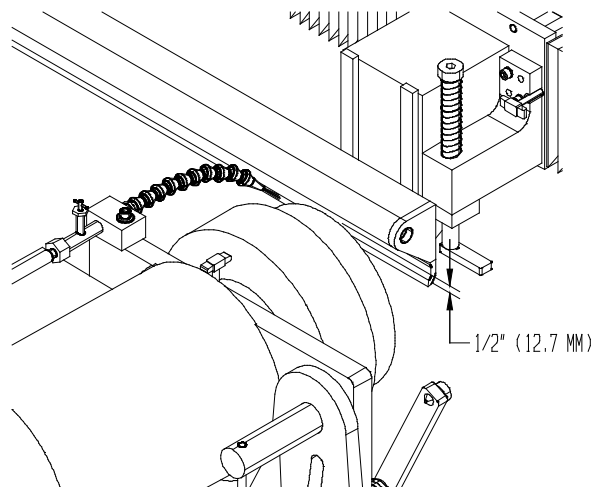

FIG. 45

IF THE GRINDING WHEEL RIM DOES NOT EXTEND OVER THE BEDKNIFE FACE, IT WILL WEAR UNEVENLY AND CAUSE GROOVES ACROSS THE SURFACE OF THE BEDKNIFE.

NOTE: The area of the grinding wheel that contacts the bedknife is on the left side of the wheel. When grinding the left end of the bedknife, the area of the wheel which doesn't contact the bedknife can remain over the bedknife. See FIG. 46. However, when you go to the right end of the bedknife, the wheel must traverse completely off the bedknife.

Check for interference:

1. Outfeed the grinding head so the wheel no longer touches the top face of the bedknife.
2. If you have just ground the front face the travel limit should still be correct. If not, follow the procedures on Page 27.
3. Infeed the grinding wheel until it very lightly touches the bedknife. Next, traverse the length of the bedknife to assure that there is sufficient clearance between the grinding wheel and the bedknife. Use the outfeed switch to back the wheel out if necessary until you can traverse the full length with only a very light touch at the closest point.

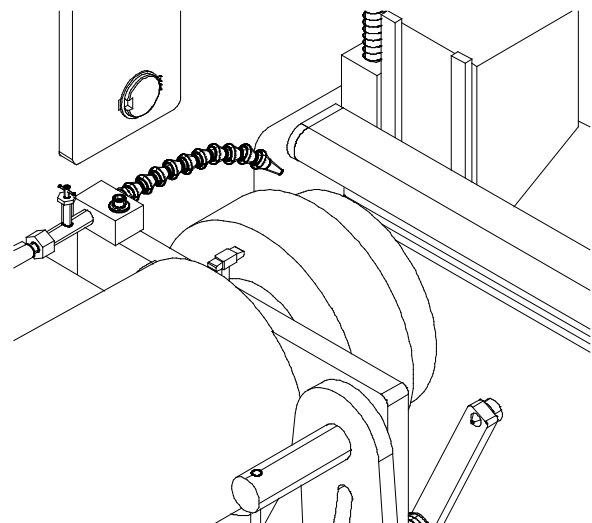

FIG. 46

THE ELECTROMAGNETS SHOULD BE ON ONLY WHEN GRINDING A BEDKNIFE. NEVER HAVE THE ELECTROMAGNETS ON FOR MORE THAN ONE HOUR, OR DAMAGE TO THE ELECTROMAGNETS MAY OCCUR.

GRINDING THE TOP FACE (Continued)

Grind the Bedknife

REFER ALSO TO THE "SAFETY RULES WHEN GRINDING" ON PAGES 8 & 9.

NOTE: At this point you won't know the condition of the grinding wheel after the previous job. Always dress the wheel before grinding. See Page 17.

1. Close the guard door.
2. Set the traverse speed knob to 15.
3. Traverse the grinding head carriage and stop at the right travel limit sensor. The LED light on the base of the sensor must be illuminated.
4. Use the program selector button to cycle through the available programs (see Page 28). Stop at the desired program. After a short pause, the machine will start all necessary motors and begin the selected grind program.
5. If the grind is too light or too heavy you may press the infeed switch during the program to move the grinding head IN or OUT .001" [.02mm] per press.
6. Continue grinding the bedknife in this manner until you are satisfied with the top face grind. Dress the wheel when necessary (see "Dressing the Grinding Wheel" on Page 22).

NOTE: During the grinding process, watch the spark pattern for the full length of grind. The sparks should look equal for the full length of grind.

REMOVING THE BEDKNIFE

Use the tooling position switch to rotate the tooling assembly down to the front face grinding position. Grasp the bedknife and turn off the electromagnet.

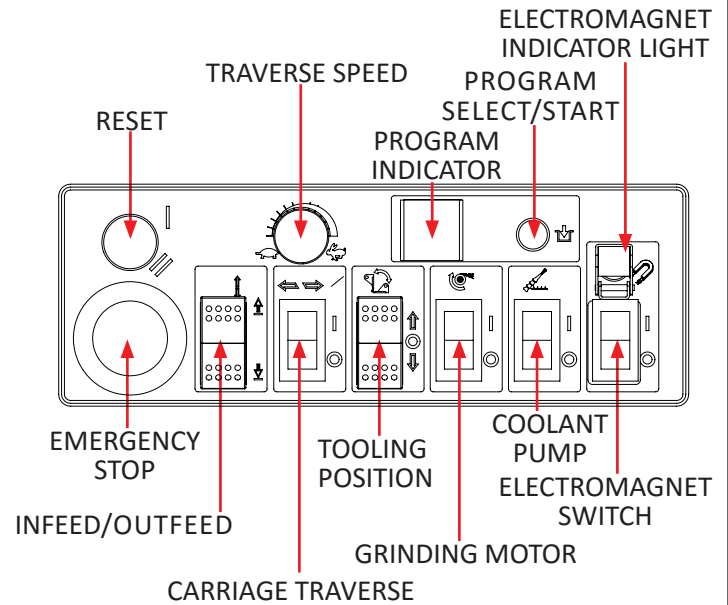

FIG. 47

ALIGNING TO A WORN BEDKNIFE

This alignment method is different than the alignment detailed on Page 26. This alignment aligns the worn bedknife face to the grinding head traverse.

Some bedknives are worn unevenly. To get the maximum life from these bed knives and remove the least amount of stock, you may want to grind them using the established surfaces for alignment.

SOME REEL ASSEMBLIES, ESPECIALLY ON GREENS MOWERS, HAVE A MINIMAL ADJUSTMENT RANGE. BE SURE THE MISALIGNMENT YOU USE IS WITHIN THE RANGE OF THE REEL ASSEMBLY SO YOU CAN ACHIEVE PROPER REEL TO BEDKNIFE ADJUSTMENT.

This is accomplished by touching the grinding wheel to the worn bedknife.

THE BEDKNIFE MAY SLIDE ON THE ELECTROMAGNETS IF YOU INFEEED THE GRINDING WHEEL EXCESSIVELY.

Here are the steps to take after the bedknife / bedbar is mounted (per the procedure on Page 26) and in the front face grinding position:

1. Move the grinding head to the left end of the bedknife. Now adjust the carriage infeed handwheel until the wheel *barely* touches the bedknife inside the unworn end nib. See FIG. 48.
2. Move the grinding head to the right end of the bedknife.
3. Without moving the grinding head infeed, loosen the lock tee knob and adjust the tooling bar right side adjuster until the grinding wheel *barely* touches the bedknife inside the unworn end nib. See FIG. 48. *NOTE: When adjusting the right side, the left side also moves a small amount, move the grinding head left and right sides several times to verify that you barely contact the knife at both ends.*
4. Lock the tee knob on the right side adjuster and check the dial indicator. The dial indicator reading difference from .500 is the amount you have adjusted the grind out of correct alignment. Make certain that this setting is within the range of adjustment of your mowing unit. (If not, a compromise offset will be required.)
5. Then, rotate the tooling bar to the top face position and repeat the above procedure to offset the top face. Grind the top face.

YOU MUST RETURN THE TOOLING ASSEMBLY RIGHT SIDE ADJUSTER BACK TO THE .500 POSITION FOR THE NEXT BEDKNIFE OR YOU WILL GRIND IT INCORRECTLY

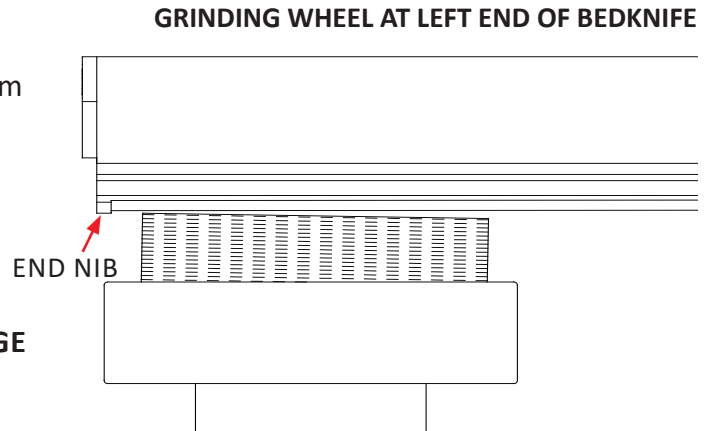

FIG. 48

GRINDING WHEEL AT RIGHT END OF BEDKNIFE

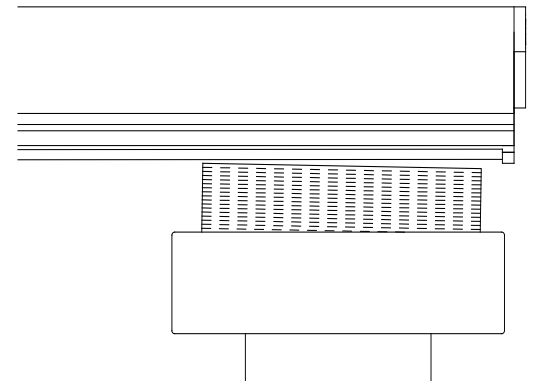

FIG. 49

ELECTROMAGNET POSITION AND THE RIGHT SIDE ADJUSTER SETTING

If the bedknife / bedbar assembly is installed in the mowing unit and it does not appear to be ground straight, the right side adjuster on the tooling bar should be checked to verify that it is parallel to the grinding head traverse rails.

To verify, use the **optional** Magnetic Base Dial Indicator (Part No. 6100501).

1. Set the top face angle pin at 0 degrees and rotate the tooling assembly to the top face grind position.
2. Install the magnet base on the top of the motor with the arm extended so the dial indicator touches the electromagnet face. See FIG. 50.
3. Disengage the traverse actuator with the release lever.
4. Slide the grinding head from magnet to magnet.
5. The dial indicator on the magnetic base should read zero (No change from magnet to magnet). If it does not, loosen the right side tooling bar adjuster lock tee knob and then adjust the right side adjuster handwheel until you get zero / zero across the two magnets.
6. Relock the T- knob.
7. Adjust the machine dial indicator which is mounted to the right side tooling adjuster so it reads .500". To adjust the position:
 - a. Loosen the set screw that holds the dial indicator.
 - b. Reposition the indicator to .500".
 - c. Retighten the set screw.

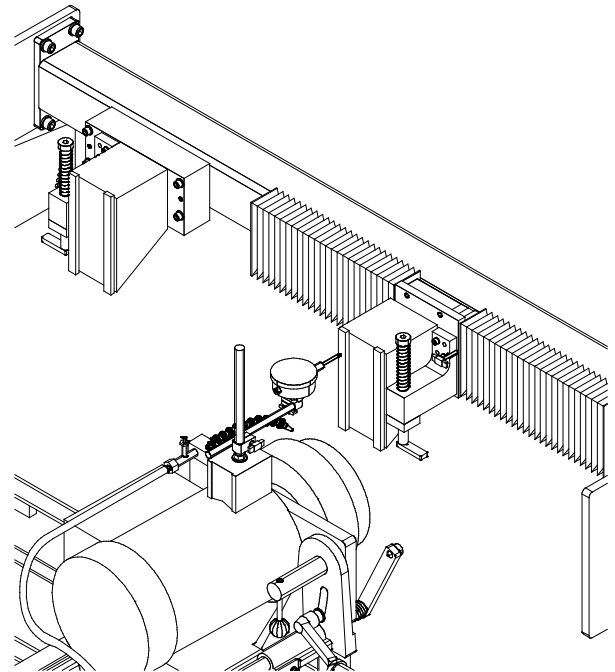

FIG. 50

CAUTION: DO NOT OVERTIGHTEN THE DIAL INDICATOR MOUNTING SET SCREW. TIGHTEN ONLY ENOUGH TO HOLD THE DIAL INDICATOR POSITION. EXCESS TIGHTNESS WILL BIND OR DAMAGE THE DIAL INDICATOR.

