



CONSTRUCTION & TREE CARE RANGE

COMPACT UTILITY LOADERS / TRENCHERS / STUMP GRINDERS / TURF RENOVATION & SPECIALTY EQUIPMENT



FROM START ■ TO ■ FINISH



From hardscape to landscape to mowing, our portfolio has you covered with a full range of solutions for the jobs you need to do. No matter what the Toro product, our entire line is designed with input from industry professionals — and our work is never finished. Our engineers continuously work on new solutions to increase productivity, ergonomics, and durability also to reduce fuel consumption, conserve water, and improve sustainability.

The result is a line of products that offers ease of use for operators at every skill level, durability to handle tough conditions, and reliability to minimise downtime and keep your operators productive. Plus, it's all backed by service and support from local Toro distributors who are dedicated to helping customers succeed.

Explore the full line of Toro Construction products at www.toroconstruction.com.au and contact your local Toro distributor to learn more.

100+ Years
FOCUSED ON
Grounds Care

400+ Patents
AROUND THE WORLD
on Toro Innovations

More Than 3%
OF TOTAL REVENUE
Is Spent on R&D

5,000+
DEALERS WORLDWIDE
To Serve You



Listening to the Industry
Groups of customers come to Toro's U.S. headquarters to discuss their needs and experiences with Toro engineers and staff. **We take that feedback and use it to develop new features and make our products better.** Continuous improvement always drives us forward.



Investing in Research
Toro is committed to investing in product development. Our passion and experience has led us to develop high quality equipment for landscape construction, with products that make your work as simple and effortless as possible — so you can get on with the job.



Supporting Contractors
We offer certified training for your maintenance technicians so they can get the most from their Toro equipment. **We stand behind our products with service and support at local distributors.** And we support many associations that help advance the industry.



Heritage
For more than 100 years, The Toro Company has focused on making equipment to maintain grounds and landscapes. From operator productivity to promoting healthy grass to conserving precious resources, our roots are in caring for the land.



Fit For All Types Environments
Toro equipment is used by some of the world's leading enterprises from rental fleets to commercial contracting as well as the finest golf courses, sports fields and landscapes.



Your True Partner
Our goal is to be more than a supplier. **We want to be the partner you go to for solutions your business needs.** From day one, Toro has been a company built on treating customers with fairness and respect. Simply put, relationships matter to us.



With deadlines to meet, operators at every skill level, and not enough time for service calls, you need products you can count on. Toro equipment gives you the durability to handle tough conditions and the reliability to keep your operators productive. And it's all backed by service and support from a local distributor who cares about your success.

At Toro, we understand the challenges you face every day because we've been there and we never stop listening to our customers. That means every product we make is designed to meet your needs. From hardscape to landscape to mowing, our portfolio has you covered with a full range of solutions to fit the jobs you need to do.

**W320-D SERIES II & W323
WHEELED COMPACT UTILITY LOADERS**

SAVE LABOUR AND FINISH FASTER

Access confined spaces you never thought possible with a wheeled compact utility loader. These models offer zero-turn capability, along with a shorter length that's easy to load on a trailer. You also get reliable hydraulic power to use a wide range of attachments. If you do a lot of tasks in tight spaces or on hard surfaces, these are the models for you.



CONTROLS

Responsive controls make the wheeled compact utility highly manoeuvrable:

- 1 Curl or dump the attachment while raising or lowering the loader arms.
- 2 Raise and lower loader arms.
- 3 Traction drive control.
- 4 Activate the auxiliary circuit control lever to power the attachments instantly.

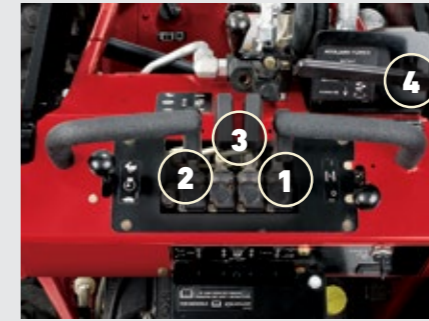

CHOOSE YOUR FUEL

A powerful diesel engine gives the W320-D extra muscle for demanding jobs, so you can dig, haul, plant, build and more. Or choose the W323 petrol which extends your working time with two durable 21.2-litre fuel tanks for a full day of work.



W320-D Series II & W323 FEATURES



HIGHLY MANOEUVRABLE
Short wheelbase design offers excellent manoeuvrability. Get into tight spaces where only hand labour could go before.



TWO TRANSPORT SPEEDS
Low speed sends more hydraulic power to the attachment and high speed sends more power to the wheels. The low speed option also helps new operators shorten their learning curve.



IMPROVED VISIBILITY
The integrated ride-on operator platform allows improved visibility of the working area and attachments.



4-PAW® INDEPENDENT FOUR-WHEEL DRIVE
Four independent wheel motors deliver hydraulic flow and pressure to all four wheels for improved traction and mobility. Fewer moving parts also mean less maintenance.

TX 700
TRACKED COMPACT UTILITY LOADERS

NEW!

POWER COMES IN COMPACT PACKAGES

Designed to give you more power in a compact package, the Toro® TX 700 expands labour savings beyond just homeowner projects. This no-nonsense workhorse packs 346.5 kg of rated operating capacity in a smaller footprint, so it's ideal for projects where homeowners and contractors are working in confined spaces. It also features patented TX 1000 traction controls that are easy to use, and a dedicated stand-on platform for increased operator comfort and visibility. And with dozens of compatible attachments, it's a versatile machine you can utilise for a wider range of jobs. With just the features you need, plus the familiarity and comforts of a Toro compact utility loader, it's an excellent solution to increase labour savings.

TX 700
Wide Track



TX 700
Narrow Track



TX 700 FEATURES



COMPACT DESIGN
Great for homeowners and contractors who need to access smaller spaces.



GENTLE ON TURF
The TX 700 offers versatile track options - a Camso narrow track for enhanced grip or a wide track version that is gentle on the turf. Choose your preferred version based on your terrain and application needs.



EASY-TO-USE CONTROLS
Effortless traction controls are easy to use for all-day productivity.



STAND-ON PLATFORM
A dedicated platform on a compact frame. Plus, the spring loaded auxiliary foot pedal increases foot space.

TX 1000
TRACKED COMPACT UTILITY LOADERS

REACH HIGHER, LIFT MORE.

The Toro® TX 1000 is a giant step forward in performance and versatility. This lightweight, manoeuvrable machine packs unmatched strength and reach in a compact package for the ultimate working advantage.

The 450 kgs plus rated operating capacity makes the TX 1000 a powerful, compact alternative to larger skid-steer loaders and other machines.



TX 1000
Narrow Track

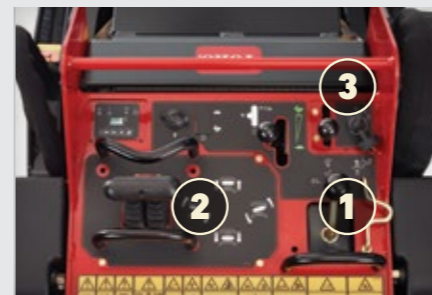

TX 1000 CONTROLS

The patented control system is exclusive to the Toro TX 1000 and provides intuitive operation that's effortless for the operator, all day long.

- 1** Curl, dump or float the bucket while raising or lowering the loader arms with one hand using the joystick.
- 2** Grab the traction drive joystick for effortless, single-hand control.
- 3** Activate the auxiliary circuit control lever to power the attachments instantly.

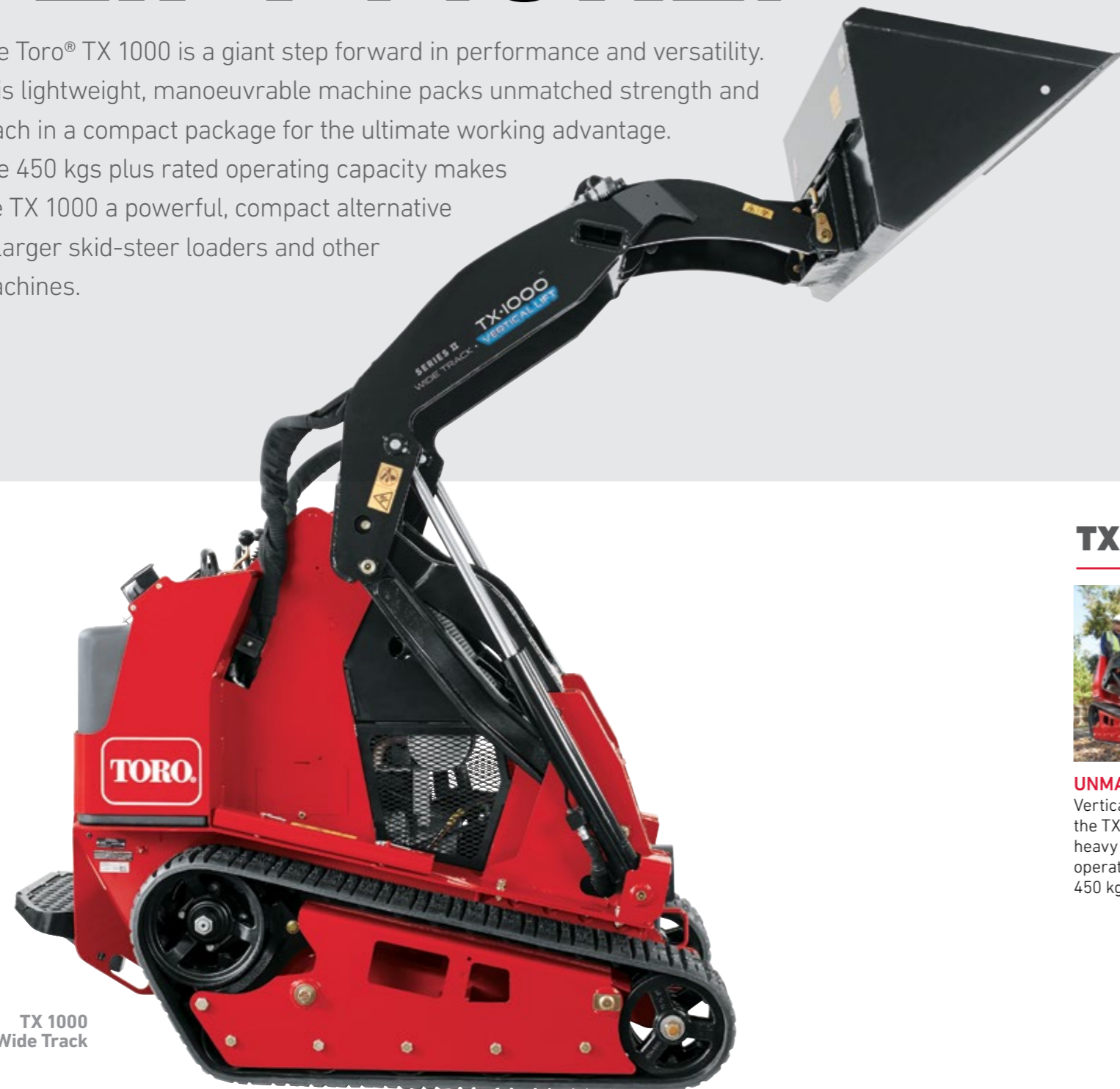

TX 1000
Wide Track

TX 1000 FEATURES



UNMATCHED STRENGTH

Vertical lift loader arms allow the TX 1000 to lift and transport heavy loads with a rated operating capacity of over 450 kg.



MAXIMUM HEIGHT AND REACH

The 206 cm hinge pin height allows attachments to easily clear the side of a large 2 m skip or large delivery van.



HIGH DRIVE TRACK SYSTEM

Ideal for the demands of any jobsite to outperform on any surface, even sand or loose gravel.

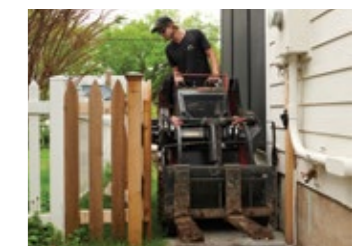

COMPACT FOOTPRINT

At 86 cm TX 1000 narrow track fits through standard 100 cm gates and at 104 cm the wide-track is just as easy to manoeuvre while offering robust stability.

ACCESSORIES

MANY ATTACHMENTS, ONE GOAL: PRODUCTIVITY

A wide variety of attachments make Toro's compact utility loaders a more cost-effective choice than a dedicated piece of equipment.

These genuine Toro® attachments are designed specifically for the machines, offering the best assurance of long life and peak performance.



Attachment Model # 22445

TORO® QUICK ATTACH SYSTEM

Change attachments in seconds

1. Mount to the attachment plate on the unit.
2. Twist the pins to locked position.
3. For powered attachments, connect hydraulic lines to dripless flush-face quick couplers on loader arms.



TREE FORK

Hydraulic fork arm opens wide to handle large trees and shrubs. Angle design allows for gentle handling of materials.



ADJUSTABLE FORKS

Easily adjust forks to desired width. Carry fence posts, rocks, pallets, plants, fertiliser, irrigation supplies and more. Forks constructed of high-strength steel.

TRENCHING, PLOWING AND BORING

Model #	Attachment Description	Dimensions (W x L x H)	Weight (kg)
22420	Bore Drive Head Attachment (Bore diameter 3.2-8.9 cm)	61 cm x 56 cm x 63.5 cm	54.4
22421	Rod and Reamer (Bore diameter 3.2-11.3 cm)	-	26.3
22472	Trench Filler	122 cm x 79 cm x 56 cm	186
22473	High-Torque Trencher Head	89 cm x 165 cm x 61 cm	177
22474	High-Speed Trencher Head	89 cm x 165 cm x 61 cm	177
22911	Vibratory Plow	74 cm x 89 cm x 61 cm	181.4

AUGERS AND TREE CARE

Model #	Attachment Description	Dimensions (W x L x H)	Weight (kg)
22429	Stump Grinder (w/chip guard)	112 cm x 51 cm x 79 cm	120
22438	Tree Fork (max load 82 kg)	62 cm x 114 cm x 32 cm	77
22586	Adjustable Fork	79 cm x 114 cm x 69 cm	73
22577	Grapple Rake	90 cm x 46 cm x 76 cm	120
22805	High-Torque Auger Power Head	61 cm x 41 cm x 58 cm	83
22806	Universal Swivel Auger Power Head	61 cm x 43 cm x 58 cm	89

AUGER BITS AND EXTENSIONS

Model #	Attachment Description
22814	46 cm (18") Auger Bit
22815	61 cm (24") Auger Bit
22816	76 cm (30") Auger Bit
22818	30 cm (12") Auger Bit Extension
22819	61 cm (24") Auger Bit Extension
22820	15 cm (6") Full Flight Auger Bit
22821	23 cm (9") Full Flight Auger Bit
22822	30 cm (12") Full Flight Auger Bit
22823	38 cm (15") Full Flight Auger Bit



Attachment Model # 22473



BORE DRIVE HEAD AND ROD & REAMER KIT

Easily bore under driveways and sidewalks to simplify irrigation and cable installations. Rod and reamer kit sold separately.



VIBRATORY PLOW

Reduce time spent on irrigation or cable installations. The vibratory plow optimises pipe-pulling performance while minimising turf damage. Tight turning radius allows for manoeuvring in confined spaces.



TRENCH FILLER

Two sets of opposing augers direct spoils into the hole. Standard float mechanism allows for up to 12.7 cm of ground following floatation. Skids evenly disperse weight and slide easily over turf, minimising damage.



HIGH-SPEED TRENCHER

Ideal for fast, efficient trenching in most soil conditions. 61 cm, 91.4 cm and 122 cm* booms available. *Longer optional spoils auger recommended for 122 cm boom.



HIGH-TORQUE TRENCHER HEAD

Guarantees performance in difficult soil conditions. 61 cm, 91.4 cm and 122 cm* booms available. *Optional spoils auger recommended for 122 cm boom.



STUMP GRINDER

Rugged design and incredible hydraulic power, the Toro stump grinder will make powder of the toughest stumps. Grinds down as far as 42 cm below grade.



HIGH-TORQUE AUGER POWER HEAD

Designed specifically to power up to 76 cm diameter augers in the toughest soil conditions. Auger bits from 15 cm to 76 cm.



UNIVERSAL SWIVEL AUGER POWER HEAD

Ensures "plumb" holes on uneven terrain up to 46 cm. Perfect for installing fences.



GRAPPLE RAKE

Grab, drag, lift and place brush and debris easily with up to 1,361 kg of clamping force at the tine tips.

ACCESSORIES

GET THE JOB DONE

Uses for the Toro® compact utility loader and its various attachments are limited only by your imagination.



Attachment Model # 22805



Attachment Model # 22577



POWER BOX RAKE

Perfect tool for seed or sod bed preparation. Carbide-teeth rotary drum pulverises rough soil, cuts high spots and fills low spots in one pass. Adjustable yoke allows 20° offset.



TILLER

Hardened steel tines for any soil condition, including clay or hardpan. Till more than 15 cm deep and 102 cm wide on one pass. Reversible tine direction frees jams.



SOIL CULTIVATOR

Bury stones, soil clods, debris and grass. Prepares seed bed in one pass, tilling soil up to 14 cm deep. Adjustable grading bar and comb teeth leave perfect germination environment.



CEMENT BOWL

Flighting mixes and holds cement in bowl. Mix, haul, and pour up to 91 kg. Auger power head required (sold separately).



LEVELER

Grade, finish, and spread topsoil and other landscape materials. Back fill trenches. Carry job site materials such as plants, fertiliser, irrigation supplies, and more.



MULTI-PURPOSE TOOL

Plant and haul trees or dig and breakup soil with the 3-in-1 ripper, towbar and boom.

EARTH MOVING EQUIPMENT

Model #	Attachment Description	Dimensions (W x L x H)	Weight (kg)
22426	Direct Drive Power Box Rake	122 cm x 124 cm x 53 cm	166
22445	102 cm (40") Tiller	112/102 cm Tilling Width x 51 cm x 66 cm	165
23102	Soil Cultivator	130 cm x 130 cm x 53 cm	165
23165	Leveler	80 cm x 105 cm x 69 cm	73

BUCKETS

Model #	Attachment Description	Dimensions (W x L x H)	Weight (kg)	Capacity (litres)
22409	4 cu.ft. Standard Bucket	107 cm x 61 cm x 35,6 cm	52	110
22410	Loose Materials Bucket	122 cm x 66 cm x 46 cm	79	180
22520	Narrow Bucket	88 cm x 68 cm x 64 cm	69	100
22340	TX 1000 Standard Bucket	104 cm x 58 cm x 38 cm	78	120
22342	TX 1000 High Volume Bucket	135 cm x 74 cm x 43 cm	115	250
-	4-in-1 Bucket Electric Hydraulic			
-	4-in-1 Bucket Hydraulic			

MATERIAL HANDLING

Model #	Attachment Description	Dimensions (W x L x H)	Weight (kg)
22423	Multi-Purpose Tool	61 cm x 10 cm x 25 cm	18
-	Boom Jib*	2 cm x 82 cm x 24 cm	10.5
-	Scarifier Teeth*	5 cm x 33 cm x 30 cm	4
22442	Cement Bowl		34
22414	Utility Blade	122 cm x 64 cm x 53 cm	96

* Available in Multi-Purpose Tool (22423)

MISCELLANEOUS

Model #	Attachment Description	Weight (kg)
23135	Hydraulic Concrete Breaker	119



Attachment Model # 22426



UTILITY BLADE

Backfill trenches, move or smooth dirt or even use to clear snow.



MANUAL OR HYDRAULIC FORKS

Transport and position trees and large shrubs exactly where you want them with exceptional manoeuvrability.



BUCKETS

Perfect for light-duty grading, levelling, and material handling. Buckets vary in capacity from 120 to 250 litres for lighter materials.

TRX-250 & TRX-300 WALK-BEHIND TRENCHERS

POWER AND SIMPLICITY SAVE YOU TIME

Toro TRX walk-behind trenchers are now more efficient and powerful than ever. We've improved our lineup with TRX-250 and TRX-300 that combine the groundbreaking manoeuvrability the TRX walk-behind trencher is known for with even better performance and serviceability.

Design enhancements make these models easier to operate, thanks to improved hydraulics and streamlined controls. Intelli-Trench™ technology automatically adjusts the hydraulic flow — putting power where you need it so you can maximise productivity. Plus, with significantly fewer parts, the TRX-250 and TRX-300 models require less maintenance.

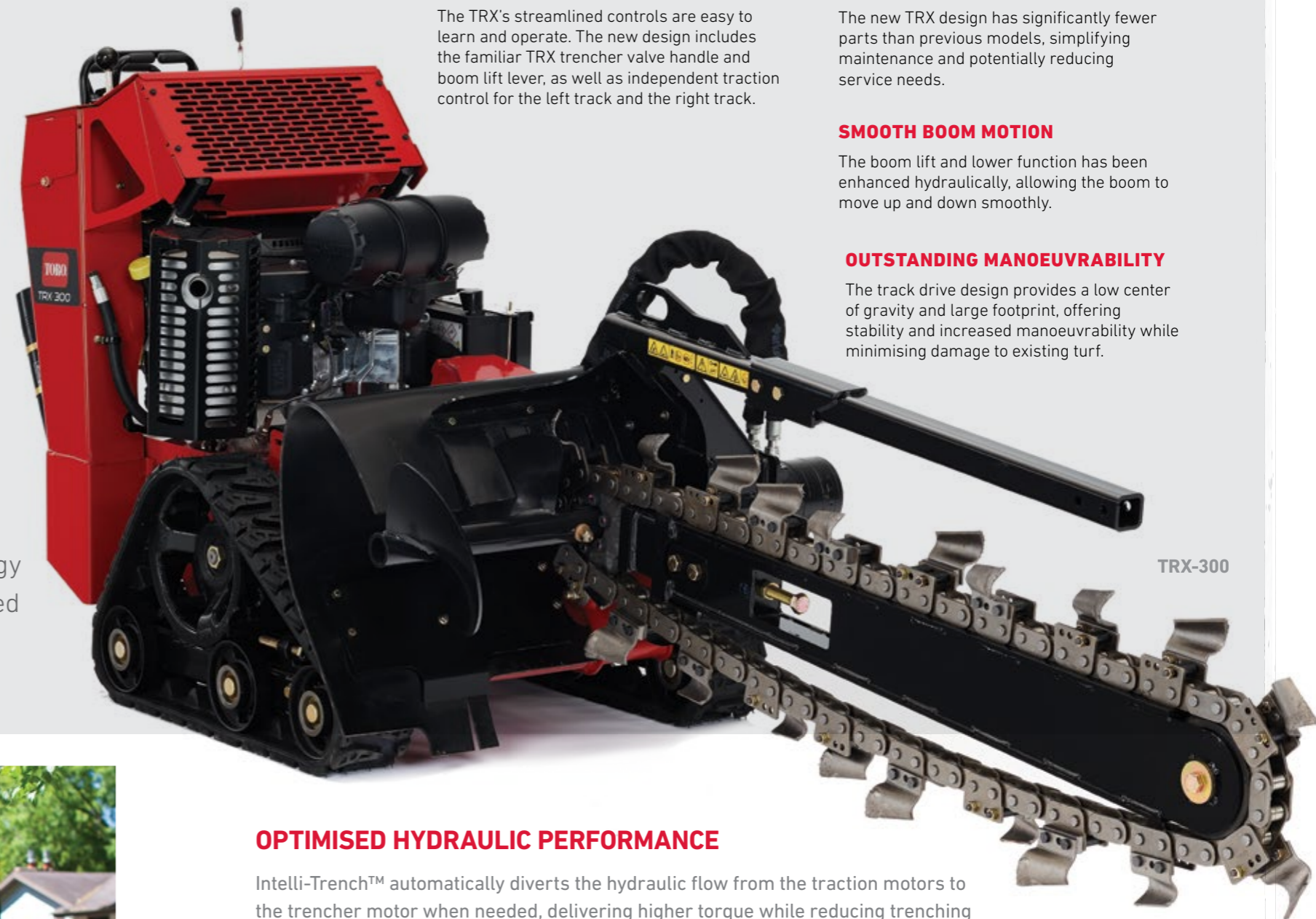

TRX-300

EASY-TO-LEARN CONTROLS

The TRX's streamlined controls are easy to learn and operate. The new design includes the familiar TRX trencher valve handle and boom lift lever, as well as independent traction control for the left track and the right track.

SIMPLIFIED SERVICE

The new TRX design has significantly fewer parts than previous models, simplifying maintenance and potentially reducing service needs.

SMOOTH BOOM MOTION

The boom lift and lower function has been enhanced hydraulically, allowing the boom to move up and down smoothly.

OUTSTANDING MANOEUVRABILITY

The track drive design provides a low center of gravity and large footprint, offering stability and increased manoeuvrability while minimising damage to existing turf.

OPTIMISED HYDRAULIC PERFORMANCE

Intelli-Trench™ automatically diverts the hydraulic flow from the traction motors to the trencher motor when needed, delivering higher torque while reducing trenching times. Track speed is also adjusted faster and more accurately, eliminating the need for constant manual adjustment of the traction controls.



TRX-250

STX-26 & STX-38 STUMP GRINDERS AND SGR-6 & SGR-13 HANDLE BAR STUMP GRINDERS

RELIABILITY DAY IN AND DAY OUT

Unlike some stump grinders, Toro's design is not over-complicated. STX-26 and STX-38 feature TX-style controls with two simple levers that are easy to learn and use. With tracked models that travel easily over muddy areas, Intelli-Sweep™ for optimal cutting performance, and transport speeds of over 6 km/h, it's the perfect combination for maximum productivity.

Toro's SGR handle bar grinders are great for grinding small stumps in areas with tight access. Well-balanced, easy to operate and simple to maintain, they provide some of the smoothest cutting performance of any handle bar stump grinder on the market.

TORO'S PATENTED, EASY-TO-USE CONTROLS

offer smooth operation with fewer levers/knobs than conventional stump grinders. An armrest near the joystick also reduces operator fatigue (available on STX-38).

- 1 Steering system (forward, reverse, turn) allows for zero-turn capability
- 2 Sweep, lift/lower and engagement of the grinder head



STX-26

STX STUMP GRINDER ADVANTAGES:

- Get optimal performance time with the hydraulically driven head — no chance of expensive belts breaking or slipping, no adjusting tension, and no cogged pulleys or clutches to replace.
- Maintain optimal performance with the Intelli-Sweep™ feature that automatically adjusts the sweep speed based on the load on the cutter wheel.
- Operate with confidence, thanks to the tracked design that offers exceptional side hill stability, as well as zero turn capability.

Both SGR-6 and SGR-13 handle bar stump grinders are compact and manoeuvrable to access hard to reach stumps and to efficiently turn stumps to mulch. Their well-balanced design and easy to use controls ensure easy operation. Each unit features convenient lift handles for easy loading and unique Greenteeth cutting technologies that combine smooth grinding with simple maintenance.



ADDED PERFORMANCE FEATURES

The STX-38 gives you superior climbing capability, manoeuvrability and greater side hill stability with a hi-drive track system. The electronic fuel injection (EFI) engine also offers easier starting, lower maintenance and improved performance. In addition, the all-hydraulic sweep control valve facilitates side-to-side feathering for superior stump grinding.

OPERATOR-FRIENDLY DESIGN

The STX-26 also offers the Intelli-Sweep™ feature, along with an offset cutting head that gives the operator excellent visibility to the stump. This model features Toro's exclusive traction control system, making it easy for new operators to learn and use.



SGR-6



SGR-13

TURF RENOVATION & SPECIALTY EQUIPMENT

DURABLE AND EASY TO MANOEUVRE

Toro's line of Turf Renovation equipment include the perfect tools for landscape contractors or homeowners with user-friendly controls, durable construction, and manoeuvrability to make overseeding an easy task.



Model# 23518 shown



61 CM (24") STAND-ON AERATOR

- Electronic depth control allows operators to provide consistent core depth and quality
- Compact design profile fits through standard 91 cm wide gates
- New Smart Hour Meter displays core depth and critical maintenance reminders

Model #	61 cm Stand-On Aerator 29516
Engine	Kohler® CH440
Fuel Capacity	7 litres
Working Width	61 cm
Aerating Depth	Up to 12.7 cm
Width	90 cm
Height	130 cm
Length	174 cm
Weight	388 kg
Ground Speed	Up to 11.2 km/h fwd Up to 3.5 km/h rev
Coverage (per hour)	1.3 acres
Tines/Blades/Broom	36 tines
Warranty*	1 Year



76.2 CM (30") STAND-ON AERATOR

- Powerful Kawasaki® V-Twin engine with integrated hydraulics
- Electronic foot pedal controls to raise and lower the tines instantly for quick zero-turn manoeuvres.
- Floating operator platform isolates the operator from vibrations for an exceptionally smooth ride.

Model #	76.2 cm Stand-On Aerator 29521
Engine	Kawasaki® FS541V V-Twin
Fuel Capacity	18.9 litres
Working Width	76.2 cm
Aerating Depth	Up to 12.7 cm
Width	121.9 cm
Height	132.1 cm
Length	162.6 cm
Weight	460.4 kg
Ground Speed	Up to 11.2 km/h fwd Up to 3.54 km/h rev
Coverage (per hour)	2.1 acres
Tines/Blades/Broom	48 tines
Warranty*	1 Year



61 CM STAND-ON AERATOR (29516)
with Seed Spreader Attachment (33525)



76.2 CM STAND-ON AERATOR (29521)
with Seed Spreader Attachment (33525)

*See your certified Toro dealers for details on all of our warranties. Separate engine manufacturer warranty.

TURF RENOVATION & SPECIALTY EQUIPMENT

EASILY CLEAR TOUGH STUMPS AND BRUSH

When you need to prepare a site for landscaping, you need equipment that works with your crew, not against it. Toro's turf renovation and specialty equipment are designed to deliver the perfect combination of user-friendly operation and easy handling to keep operators working efficiently all day, every day. Plus, with Toro's commercial-grade durability, you can count on reliable performance job after job, even in challenging conditions.



Model #	POWER BROOM 38701
Engine	7 hp Kohler CH270 Command 208 cc
Steering	Power steering with clutch left & right hand
Transmission	Friction Disc
Fuel Capacity	4.1 litre
Broom Angle	40° total - 20° left/20° right
Broom Width	91.4 cm with 18 wafers
Broom Diameter	63.5 cm
Broom Speed	200 RPM
Broom Drive	Direct
Weight	151 kg
Starter	Recoil
Tyres	40.6 cm x 11.4 cm - 15.2 cm
Warranty*	1 Year



Model #	BRC-28 Brush Cutter 23522
Engine	14.5 hp Toro single cylinder 452 cc
Electric Start	Standard
Cutting Width	71.1 cm
Cutting Height	9.5 cm
Fuel Capacity	3.8 litre
Deck	50 ksi high strength steel Pivoting +/- 10 degrees w/spring return
Spindle Diameter	3.5 cm
Transaxle	Hydro-Gear T2
Dimensions (LxWxH)	225 cm x 88.9 cm x 110.3 cm
Weight	170.6 kg
Warranty*	1 Year



POWER STEERING

The Power Broom's Power Steering enables wheels to be disengaged independently or simultaneously with trigger controls - making turning, reversing and steering easy for anyone.



HARDWORKING PERFORMANCE

The Toro BRC-28 hydro drive brush cutter levels brush, tall weeds, saplings and heavy vegetation with ease. This model features a pivoting deck with a flail blade that handles brush up to 1.8 m tall and saplings up to 5 cm in diameter. Standard electric start, large fuel tank capacity and the 71 cm cutting deck increase operator productivity. You can also easily manoeuvre this powerful machine in both forward and reverse with the one-hand control feature.

*See your certified Toro dealers for details on all of our warranties. Separate engine manufacturer warranty.

COMPACT UTILITY LOADER RANGE



TX 700 & TX1000 SPECIFICATIONS

NEW!

	TX 700 NARROW TRACK 22351	TX 700 WIDE TRACK 22352	TX 1000 NARROW TRACK 22327	TX 1000 WIDE TRACK 22328
Wheelbase	99 cm (39")		104 cm (41")	
Ground Clearance	13.3 cm (5.25")		15.2 cm (6.0")	
Overall Width	86.9 cm (34.2") w/ bucket	105.2 cm (41.4") w/ bucket	86.8 cm (34.2")	104 cm (41")
Overall Length	261.1 cm (102.8") w/ bucket; 208 cm (81.7") w/o bucket		256 cm (100.7") w/bucket; 208 cm (81.7") w/o bucket	
Overall Height	140.5 cm (55.3")		135 cm (53.2")	
Max Operating Height	246.4 cm (97")		267 cm (105")	
Hinge Pin Height	186.7 cm (73.5")		206 cm (81")	
Dump Height	134.4 cm (52.9")		155 cm (61")	
Dump Angle	42 degrees		40 degrees	
Reach - Fully Raised	78.7 cm (31")		62 cm (24.5")	
Ground Speed (F/R)	0-7.2 km/h forward and reverse		0-6.1 km/h forward and reverse	0-7.6 km/h forward and reverse
Weight	1,140.3 kg (2,514 lbs)	1,180.2 kg (2,602 lbs)	1,263.2 kg (2,785 lbs)	1,265.5 kg (2,790 lbs)
Tip Capacity	989.7 kg (2,182 lbs)		1,296 kg (2,857 lbs)	1,393 kg (3,071 lbs)
Rated Operating Capacity (35% of Tip Capacity) ^A	346.5 kg (764 lbs)		453.5 kg (1,000 lbs)	487.6 (1,075 lbs)
Engine	Yanmar® 3TNV80F		Kubota® D1305	
Manufacturer's Gross HP Rating at RPM ^{**}	18 kW (24.5 hp) @ 3000 rpm		18.5 kW (24.8 hp) @ 2600 rpm	
Displacement	1,267 cc (77.31 cu. in.)		1,261 cc (76.95 cu. in.)	
Fuel Type	Diesel		Diesel	
Air Filter	Remote single element		Heavy-duty, remote	
Cooling System	Combo downflow radiator and oil cooler		Liquid Cooled	
Fuel Tank	20.8 litres (5.5 gallons)		41.64 litres (11 gallons)	
Oil Capacity	3.4 litres (3.6 quarts)		5.7 litres (6.0 quarts)	
Loader Arms	Radial		Vertical	
Hydraulic Pressure	3,000 psi		3,000 psi	
Hydraulic Flow	Traction: 14.5 gpm (each pump); Auxiliary: 13.7 gpm		Traction: 11.1 gpm imperial (each pump); Auxiliary: 12.7 gpm imperial	
Reservoir Capacity	37.9 litres (10 gallons)		37.9 litres (10 gallons)	
Tracks	Camso B-Tread	Camso Turf Friendly	Sprocket-drive, 6 road wheels per side	
Traction	Dual hydrostatic pump		Dual hydrostatic pump	
Track Length x Width	321.6 cm x 13.7 cm (126.6" x 5.4")	321.6 cm x 23.1 cm (126.6" x 9.1")	324 cm x 15 cm (127.6" x 5.9")	324 cm x 24 cm (127.6" x 9.5")
Ground Pressure (traction unit weight only)	6.4 psi	4.8 psi	5.6 psi	3.6 psi
Warranty [*]	2 years or 1000 hours (whichever occurs first)		2 years or 1000 hours (whichever occurs first)	

^APer ISO 14397-1
^{**}Per SAE 1995

W323 & W320-D SERIES II SPECIFICATIONS

	W323 22318	W320-D 22337CP
A Wheelbase	71 cm (28")	
B Ground Clearance	15 cm (5.8") front & rear	
Overall Width	103 cm (40.5") standard tyres; 90 cm (35") narrow tyres	
C Overall Length	208.8 cm (82.2") w/bucket; 157.5 cm (62") w/o bucket	
D Overall Height	123.7 cm (48.7")	
E Max Operating Height	231.6 cm (91.2")	
F Hinge Pin Height	167.6 cm (66")	
G Dump Height	119 cm (47")	
H Dump Angle	34 degrees	
I Reach - Fully Raised	71.1 cm (28")	
Ground Speed	0-6 km/h (0-3.7 mph) forward or reverse	0-4.8 km/h (0-3.0 mph) forward or reverse
Weight	711 kg (1,567 lbs)	781 kg (1,722 lbs)
Tip Capacity	467 kg (1,030 lbs)	475.4 kg (1,048 lbs)
Rated Operating Capacity (50% of Tip Capacity) ^A	234 kg (515 lbs.)	238 kg (524 lbs.)
Engine	Kohler® Command Series CH235	Kubota D722
Manufacturer's Gross HP Rating at RPM ^{**}	17.2 kW (23 HP) @ 3600 rpm	14.9 kW (20 HP) @ 3600 rpm
Displacement	674cc (41 cu. in.)	719cc (43.88 cu. in.)
Fuel Type	Petrol	Diesel
Air Filter	Heavy-duty, remote	
Cooling System	Air Cooled	Liquid Cooled
Fuel Tank	42.4 litres (11.2 gallon)	15 litres (4 gallon)
Oil Capacity	1.9 litres (2 quarts)	3.2 litres (3.4 quarts)
Loader Arms	Radial	
Hydraulic Pressure	224.1 bar (3,250 psi)	
Hydraulic Flow	9 gpm high-flow hydraulic circuit, 3.4 gpm low-flow hydraulic circuit	
Reservoir Capacity	64 litres (17 gallons)	56 litres (14.8 gallons)
Warranty [*]	2 Years or 1000 Hours (whichever occurs first)	

^APer ISO 14397-1
^{**}Per SAE 1995

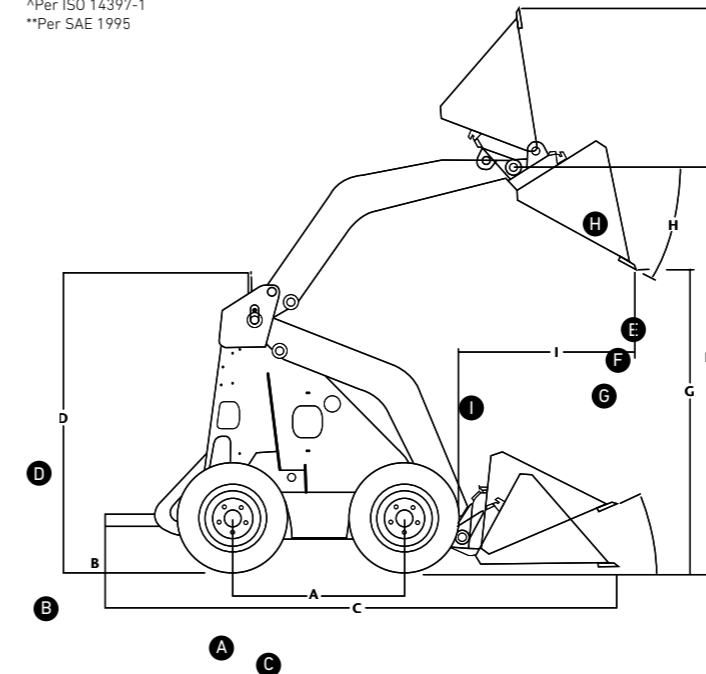

^{*}See your certified Toro dealers for details on all of our warranties. Separate engine manufacturer warranty.

We reserve the right to improve our products and make changes in specifications, design and standard equipment without notice and without incurring obligation. ^{*}See your certified Toro dealers for details on all of our warranties. Separate engine manufacturer warranty.

STX RANGE



STX-38 & STX-26 SPECIFICATIONS

	Model #	STX-38 23214	STX-26 23208
ENGINE	Engine	Kohler® Command PRO® ECV980 980cc (28.3 kW) 38 hp 4-cycle petrol air-cooled engine	Kawasaki® FX730V 726cc (19.3 kW) 26 hp 4-cycle petrol air-cooled engine
	Cooling System	Air	Air
	Fuel Tank	35 litres (7.7 gallons)	18 litres (4 gallons)
	Oil Capacity	1.9 litres (2 quarts)	1.8 litres (1.9 quarts)
	Starter	Electric Start	Electric Start
	Hour Meter	Standard	Standard
	Transport Speed	7.2 km/h (4.5 mph)	6.8 km/h (4.2 mph)
HYDRAULIC SYSTEM	Flow Rate	57 L/min (15 gpm) to each side; gear pump with a flow rate of 75.7 L/min (20 gpm) to the piston engine that drives the cutting head	51.1 L/min (13.5 gpm) hydraulic flow to cutter head; 38 L/min (10 gpm) hydraulic flow to each track
	Capacity	38 litres (10 gallons)	23 litres (6.1 gallons)
	Hydraulic Oil Cooler	Standard	Standard
TRACK	Size, Material	15 cm (5.9") wide – Aramid reinforced rubber track	15 cm (5.9") wide – endless nylon reinforced rubber track
	Track Drive	Sprocket-drive; 3 road wheels per side Traction dual hydrostatic pump	Sprocket-drive; 3 road wheels per side Traction dual hydrostatic pump
RAD	Cutting Wheel	57 cm (22.4") Diameter to Tooth, 2.5 cm (1") Thick, 16 Greenteeth® Cutting Teeth	48 cm (18.9") Diameter to Tooth, 1.9 cm (.75") Thick, 12 Greenteeth Cutting Teeth
	Cutting Depth	45.7 cm (18") Below Grade	32 cm (12.6") Below Grade
	Cutting Height	89 cm (35") Above Grade	84 cm (33") Above Grade
	Head Swing	132 cm (52") radius x 60° sweep arc	119.3 cm (47") radius x 90° sweep arc
DIMENSIONS	Weight	794 kg (1,750 lbs)	544 kg (1,199.3 lbs)
	Dimensions (LxWxH)	241.3 cm x 86.3 cm x 129.5 cm (95" x 34" x 51")	198 cm x 86.3 cm x 116.8 cm (78" x 34" x 46")
WARRANTY*		2 years or 1000 hours (whichever occurs first)	2 years or 1000 hours (whichever occurs first)

SGR RANGE

SGR-6 & SGR-13 SPECIFICATIONS



Model #	SGR-6 22600
Engine	6.5 hp Honda® GX200
Clutch	Centrifugal
Wheel	24.1 cm diameter cutter wheel
Cutter Depth	15 cm below grade
Cutter Height	25.4 cm above grade
Belt	Single 2V belt
Dimensions (WxLxH)	56 cm x 127 cm x 107.4 cm
Weight	47 kg
Warranty*	1 year



Model #	SGR-13 22615
Engine	13 hp Honda® GX390
Clutch	Centrifugal
Wheel	24.1 cm diameter cutter wheel
Cutter Depth	28 cm below grade
Cutter Height	35.6 cm above grade
Belt	Single 3V belt
Dimensions (WxLxH)	73.7 cm x 185.4 cm x 104 cm
Weight	109 kg
Warranty*	1 year

*See your certified Toro dealers for details on all of our warranties. Separate engine manufacturer warranty.

TRX RANGE



TRX-250 & TRX-300 SPECIFICATIONS

	Model #	TRX-250 22983	TRX-300 22984
POWER SYSTEM	Engine	24.5 hp (18.3 kW) @ 3,600 rpm Toro® V-twin	26.5 hp (19.8 kW) @ 3,600 rpm Kohler® ECV749, EFI
	Cooling System	Air Cooled	Air Cooled
	Fuel Tank	15.1 litres (4 gallons)	15.1 litres (4 gallons)
	Oil Capacity	2.4 litres (2.5 quarts)	1.9 litres (2 quarts)
	Start Method	Electric	Electric
	Hour Meter	Standard	Standard
	Transport Speed	3.9 km/h / 2.4 km/h 64.3 m/min / 40.2 m/min	3.7 km/h / 2.4 km/h 61.6 m/min / 40.2 m/min
HYDRAULIC SYSTEM	Hydraulic Pressure	184 bar (2,670 psi)	180 bar (2,610 psi)
	Hydraulic Flow	Trencher: 50.0 lpm (13.2 gpm) Traction: 61.3 lpm (16.2 gpm) Transport 11.4 lpm (3.0 gpm) Trenching	Trencher: 50.0 lpm (13.2 gpm) Traction: 61.3 lpm (16.2 gpm) Transport 11.4 lpm (3.0 gpm) Trenching
	Reservoir Capacity	23.8 litres	23.8 litres
Hydraulic Oil Cooler	Standard	Standard	
HEADSHAFT SPEED		210 rpm with 334.64 m/kg of torque	210 rpm with 334.64 m/kg of torque
TRACKS	Width	15 cm (5.9") wide – endless nylon reinforced rubber	15 cm (5.9") wide – endless nylon reinforced rubber
	Drive	Sprocket-drive, 3 road wheels per side	Sprocket-drive, 3 road wheels per side
	Traction	Two-section hydraulic pump with two hydraulic motors (one for each track)	Two-section hydraulic pump with two hydraulic motors (one for each track)
GROUND PRESSURE		61 cm (24") boom = 0.28 bar (4.1 psi) 91 cm (36") boom = 0.30 bar (4.4 psi) 122 cm (48") boom = 0.31 bar (4.5 psi)	61 cm (24") boom = 0.28 bar (4.1 psi) 91 cm (36") boom = 0.30 bar (4.4 psi) 122 cm (48") boom = 0.31 bar (4.5 psi)
DIMENSIONS	Overall Dimensions with 24" Boom Up & Chain (WxLxH)	86 cm x 210 cm x 117 cm (33.8" x 82.5" x 46")	86 cm x 210 cm x 117 cm (33.8" x 82.5" x 46")
	Wheelbase	58 cm	58 cm
	Weight	501 kg	505 kg
BOOM OPTIONS	Depths	61 cm, 91 cm and 122 cm (24", 36" and 48")	61 cm, 91 cm and 122 cm (24", 36" and 48")
	Widths	10 cm and 15 cm (4" and 6")	10 cm, 15 cm and 20 cm (4", 6" and 8")
WARRANTY*		2 years or 1000 hours (whichever occurs first)	2 years or 1000 hours (whichever occurs first)

**20 cm (8-in) chain conversion kit available through parts only

We reserve the right to improve our products and make changes in specifications, design and standard equipment without notice and without incurring obligation.

*See your certified Toro dealers for details on all of our warranties. Separate engine manufacturer warranty.

GENUINE TORO PARTS, AFTERMARKET SUPPORT

FOR PEACE OF MIND INSIST ON TORO GENUINE PARTS

To best protect your investment and maintain optimal performance of your construction, tree care, turf renovation and specialty equipment, count on Toro genuine parts. When it comes to reliability, Toro delivers replacement parts designed to the exact engineering specifications of our equipment.



AIR FILTER



FUEL FILTER



OIL FILTER



TOUCH-UP PAINT
- CAN AND PEN



TYRES



RESPONSIVE TORO DEALERS

Toro dealers have the skills, training and commitment to keep your equipment performing its best. Leveraging their extensive inventory and Toro's industry-leading fill rate on parts, your Toro dealer leads the market in parts availability.

VISIT YOUR LOCAL TORO DEALER

Count on our national network of certified dealers for genuine Toro parts and service support. Toro construction and tree care equipment dealers regularly undergo extensive technical training to stay knowledgeable about the servicing and operation of new products.

TORO. COUNT ON IT.

COMPREHENSIVE WARRANTY COVERAGE

Toro stands behind its equipment with comprehensive warranty coverage (see your Toro dealer for complete details).

- 2 year or 1000 hour[^] limited warranty* on all compact utility loader traction units, STX stump grinders, walk-behind trenchers and attachments^{^^}.
- 1 year limited warranty* on all SGR handle bar stump grinders and turf renovation and specialty equipment

[^]Whichever occurs first.

^{^^}The 4 in 1 bucket attachments and associated components have a 6 month warranty.

*Separate engine manufacturer warranty.

CUSTOM FINANCE FACILITY



Toro can facilitate custom finance packages at market-leading rates with a simple application process, and pre-approved lines of credit.

With finance terms ranging from 12 through to 66 months, and the flexibility of tailoring a repayment structure to match your cashflow requirements, you can count on a Toro Finance option to meet your needs.

For more information, contact your local certified Toro dealer.



PROTECT YOUR INVESTMENT STABILISE YOUR BUDGET

Toro Protection Plus (TPP) is comprehensive protection for new Toro equipment. The coverage is essentially the same as with the standard Toro warranty and provides extensive protection against mechanical breakdown beyond the warranty period.

TPP provides seamless coverage – whenever the Toro Warranty expires (either after the time period or because the total hours have been reached), TPP is there to continue coverage against mechanical breakdowns.

See your local dealer for more information.

SAFETY AND PERFORMANCE FOR YOU AND YOUR EMPLOYEES

Toro has a longstanding reputation for designing safe products. Every piece of Toro equipment is rigorously tested to strict requirements.

SAFETY EDUCATION FOR YOU AND YOUR EMPLOYEES

At Toro, we produce our machines with safety in mind and test against rigorous safety standards, but it doesn't stop there. We offer tools to help train and protect you and your crew – and help safeguard your business. From on-line operator's manuals to product safety and training videos, all to assist and reinforce safe operation of our products and to further enhance the training of operators and keep them safe.

PERFORMANCE EVALUATIONS

Each new Toro product is subjected to extensive high-tech testing at Toro's corporate headquarters, as well as extensive field evaluations in various types of working and operational conditions. Even after all of this testing, we still place product samples in the field with equipment professionals to ensure the machines and attachments perform as intended.





TX 700
Narrow Track



Count on it.



toro.com.au

Toro Customer Service 1800 356 372

Toro Australia Head Office
 53 Howards Road
 Beverley SA 5009
 Ph: +61 8 8300 3633
 Fax: +61 8 8243 2940

©2023 The Toro Company.
 All Rights Reserved.

IND-C0256
 11-2023

Products depicted in this literature are for demonstration purposes only. Actual products offered for sale may vary in use, design, required attachments and safety features. We reserve the right to improve our products and make changes in specifications, designs, and standard equipment without notice and without incurring obligation. The gross horsepower of the engines have been laboratory rated by the various engine manufacturers. As configured to meet safety, emission and operating requirements, the actual engine horsepower on this class may be significantly lower.

Many of the products you will find in certified Toro dealers' stores come with a warranty or guarantee from The Toro Company. In addition, our goods come with guarantees that cannot be excluded under the Australian Consumer Law. You are entitled to a replacement or refund for a major failure and for compensation for any other reasonably foreseeable loss or damage. You are also entitled to have the goods repaired or replaced if the goods fail to be of acceptable quality and the failure does not amount to a major failure. Full details of your consumer rights may be found at www.consumerlaw.gov.au

**See your certified Toro dealers for details on all of our warranties.*

FOLLOW US!



facebook.com/toroaus
twitter.com/toroaus
instagram.com/toroaus
au.linkedin.com/showcase/toroaustralia
youtube.com/toroaustralia

